

instruction book

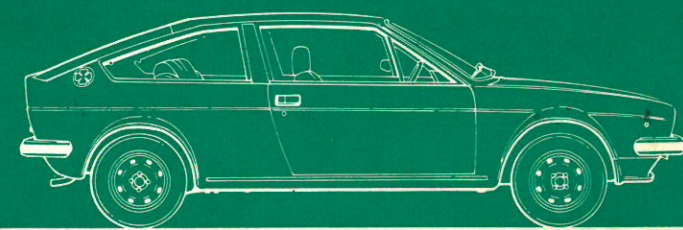

Alfasud Sprint 

CONTENTS

2 - GUARANTEE - SERVICE COUPON BOOK - SERVICE NETWORK

How to use your car

4 - CONTROLS AND INSTRUMENTS
6 - Keys - Starting the engine - Antitheft
7 - Light switch - Turn signal - Horn
8 - Blower/Demister - Gearlever - Wheel rack adjustment - Screen wiper and washer pump
9 - PRECAUTIONS
Starting from cold and with hot engine - While driving
10 - While parking - Winter precautions
11 - Tyre chains - Running in - Stopping distance
12 - VENTILATION, DEMISTING AND HEATING
Air flow control
13 - Temperature control - Electric blower - Air discharge - Heated backlight
14 - INTERIOR
Sun visors - Rearview mirror
15 - Cigarette lighter - Glove compartment - Ash tray - Courtesy lights
16 - Front seats
17 - Seat belts
18 - Doors and windows
19 - ENGINE BONNET
20 - TAILGATE
22 - WHEEL CHANGE - TOWING

Maintenance

24 - LUBRICATION
Lubrication schedule - Oil level checking

IMPORTANT NOTICE TO OWNER

If you should have a problem or question concerning the servicing of your car, write or phone either your Selling Agent or your local Alfa Romeo Distributor. The name and address of the one nearest you appears in the "Guide to Service Network".

25 - Oil change - Renewing oil filter - Checking and changing gearbox/differential oil
26 - INSPECTION - ADJUSTMENT
Maintenance schedule
27 - Air filter - Alternator and pump drive belt
28 - Carburettor
29 - COOLING SYSTEM
30 - Draining and replenishing the system
31 - BRAKES
32 - Clutch and brake fluid reservoir - Cleaning instructions
33 - WHEELS
Tyres - Changing over - Balancing
BODY MAINTENANCE
Changing wiper blades
34 - Screen washer - Washing the car - Polishing - Cleaning the windows - Upholstery
LAYING THE CAR UP
35 - ELECTRICAL EQUIPMENT
Battery - Alternator - Spark plugs - Contact gap
36 - Headlamp beam setting
37 - Replacing bulbs
40 - Fusebox - Radio installation

General data

42 - SPECIFICATION
Engine - Chassis - Performance
43 - Valve timing and clearance - Ignition advance - Carburettor setting - Ratios - Front wheel toe-out
44 - IDENTIFICATION
45 - TRAILER HITCH INSTALLATION
48 - WIRING DIAGRAM
Cable colour code

Inside backcover
LUBRICANTS - TYRE PRESSURES - CAPACITIES

WARNING

Beware of the danger of carbon monoxide! Never run the engine in an enclosed space. The exhaust gases contain carbon monoxide, a deadly gas. Carbon monoxide is particularly dangerous as, being it colourless odourless and tasteless, its presence is very difficult to detect.

The operation and maintenance instructions contained in this handbook MUST BE CAREFULLY OBSERVED by every owner who desires to get the best from this vehicle and to ensure a long life for every component. Owners are recommended, in their own interest, to entrust all maintenance and repair work to an AUTHORIZED ALFA ROMEO SERVICE STATION as such Stations are equipped with the proper tools and staffed by specially trained mechanics who are kept up-to-date by our technical literature.

Owners are reminded that Alfa Romeo cannot be responsible for any errors made by unauthorized service stations.

Only use GENUINE SPARE PARTS and/or lubricants as recommended.

ALFA ROMEO - DIREZIONE ASSISTENZA TECNICA

The data relating to weights, consumptions and speeds are approximate only; Alfa Romeo reserves the right to change without notice any features and data given in this book. Some of the equipments are optional extras. Refer to price list for a comprehensive list of optionals.

GUARANTEE

The supplier guarantees the products of the Factory as guaranteed by the Manufacturer (who guarantees exclusively the products of normal manufacture) for 6 months from the date of delivery to the Customer.

The guarantee does not cover tyres and non-essential accessories if made by third parties.

The guarantee covers the free repair of, or free supply and replacement of, any parts found to be unserviceable because of an acknowledged defect of materials: defects will be acknowledged after prior investigation of them and of their cause exclusively by the manufacturer's workshops or by workshops authorized by the manufacturer, and at the said workshops. Delays, if any, shall not entitle the Purchaser to receive compensation for damages, nor to any extension of his rights under the guarantee.

The guarantee shall automatically lapse:

- if the products are used otherwise than in accordance with the manufacturer's instructions;
- if they are modified, repaired or dismantled, even if partially, elsewhere than in the manufacturer's workshops or workshops authorized by the manufacturer;
- if bodies of different origin which have not been previously approved by the manufacturer are fitted to the chassis.

The Purchaser shall not be entitled, in any of the cases stipulated by this article, to claim cancellation of the Contract or compensation for damages.

SERVICE COUPON BOOK

The Service Coupon Book, supplied with every vehicle, bears the conditions that govern the provision of Alfa Romeo Services and the replacement of damaged parts during the period covered by the guarantee.

The Service Coupon Book includes **one coupon covering certain free maintenance** (lubricants, filters and/or filter elements and normal wear service items are to owner's account) during the guarantee period; the Purchaser must use the coupon on completion of the mileage as stated thereon.

SERVICE NETWORK

The Alfa Romeo Services in Italy and abroad are listed in the Guide supplied with every vehicle. In any event rely on your Alfa Romeo Agent who display the shield with the Alfa Romeo emblem and name.

The Alfa Romeo Services in Italy are also entered in the telephone directory under « A » Alfa Romeo.

HOW TO USE YOUR CAR

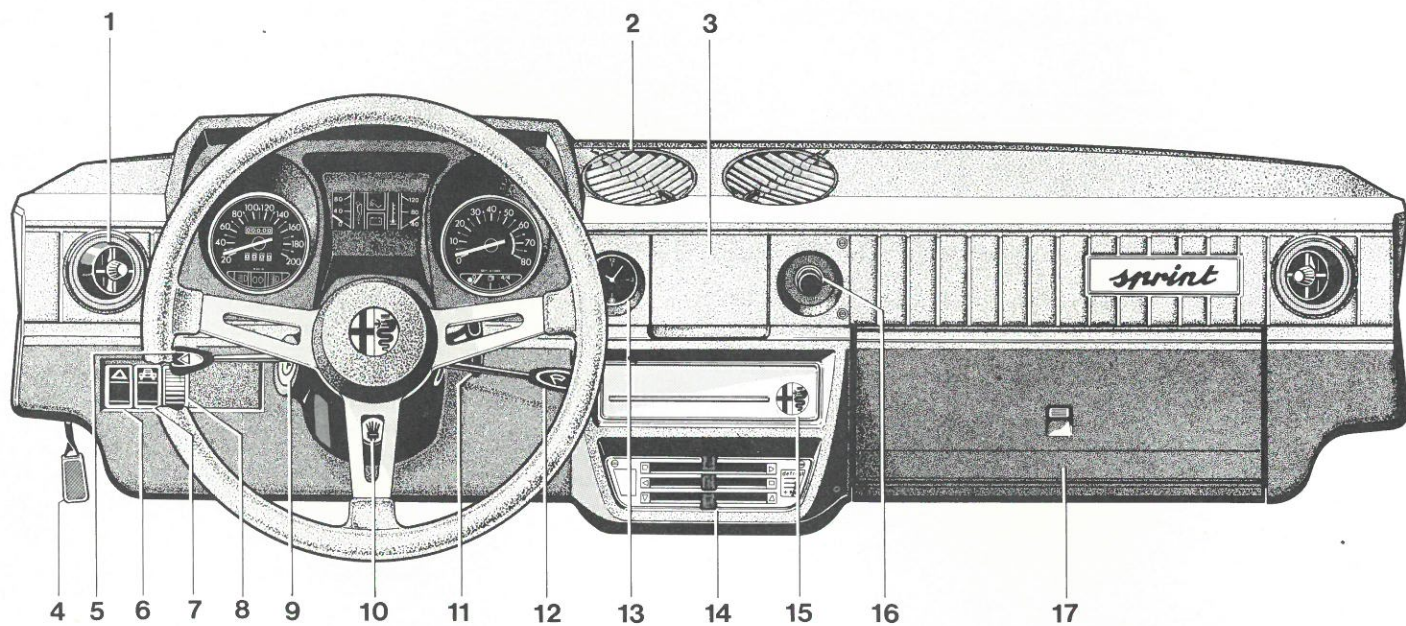

CONTROLS AND INSTRUMENTS

- | | |
|---|---|
| 1 - Ram air vent | 9 - Ignition switch and antitheft |
| 2 - Windscreen demisting outlet | 10 - Choke |
| 3 - Ash tray | 11 - Adjustable wheel lever |
| 4 - Bonnet catch release | 12 - Switch controlling horn, screen wiper, blower and screen washer pump |
| 5 - Switch controlling parking lights (and lighting of instruments, heater control panel, ash tray and lighter) headlamps, flashing, direction indicators | 13 - Electronic clock |
| 6 - Road hazard light switch | 14 - Ventilation and heater control panel |
| 7 - Heated rear window switch & telltale | 15 - Provision for radio set |
| 8 - Dimmer of instrument, clock, heater control panel lights and parking lights telltale | 16 - Cigarette lighter |
| | 17 - Glove compartment |

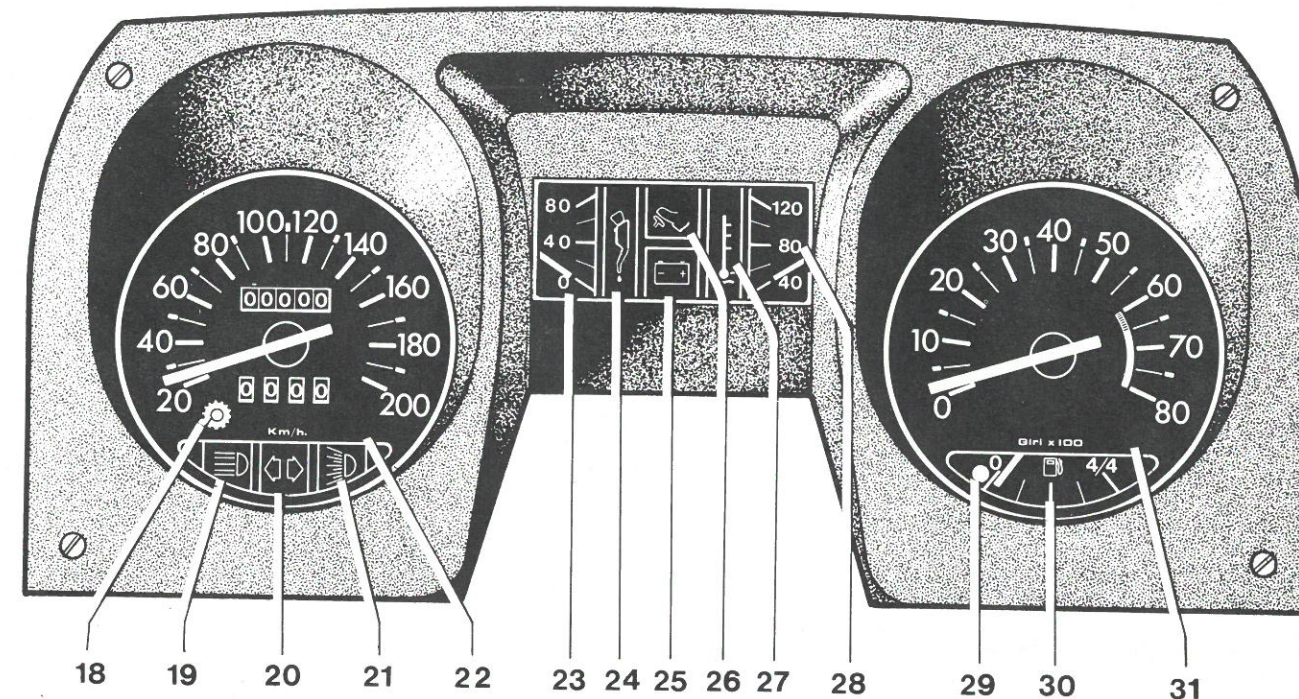

- | | |
|--|--|
| 18 - Trip odometer reset | 25 - Alternator warning light |
| 19 - High beam warning light | 26 - Choke warning light and low brake fluid level warning light |
| 20 - Direction indicator warning light | 27 - Coolant temperature warning light |
| 21 - External light warning | 28 - Coolant thermometer |
| 22 - Speedometer | 29 - Fuel reserve warning light |
| 23 - Oil pressure gauge | 30 - Fuel level indicator |
| 24 - Oil pressure warning light | 31 - Tachometer |

Ignition and antitheft device key

SYMBOL

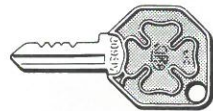

SYMBOL

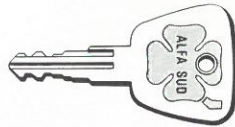

Key to doors

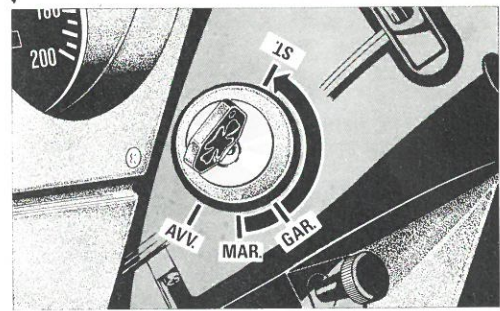
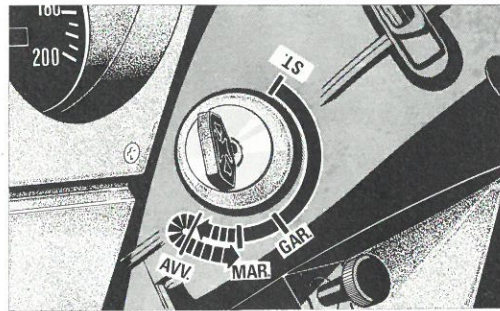

KEYS

It is a good rule to keep a record of the symbol stamped on the key handle. When ordering duplicate keys, please quote the symbol.

STARTING THE ENGINE

Insert the key in the ignition switch and turn it clockwise to "AVV" (starting). While doing this, when the key is at "MAR" position (ignition "on") the warning lights for alternator, engine oil pressure, coolant temperature (engine cold), choke (if engaged) will come on. As soon as engine starts, release the key.

If the engine fails to start, the key must be returned to "GAR" and the operation repeated.

When engine is running the following warning lights should go off: alternator telltale (as soon engine speed exceeds idling), oil pressure telltale and coolant temperature telltale (with hot engine only).

STOPPING THE ENGINE

Return the key anticlockwise to "GAR" (garage).

ANTITHEFT / STEERING LOCK

Turn the key back to ST. By withdrawing the key the steering is locked; to engage the lock properly slightly rotate the wheel in both directions.

Warning: Never withdraw the key before the car has come to a complete stop.

To release the steering lock insert the key and turn it clockwise. To help, slightly rotate the wheel in both directions.

LIGHT SWITCH

Note: The lights (except reversing lights) are wired independently from the ignition switch.

1 - Flashing

Pull the knob toward the wheel (flashing is always possible except when high beams are on).

2 - Parking lights and number plate light

To switch them on turn the knob to the first notch. The green warning light in facia panel will light up. The lights for illumination of instruments, heater control panel, clock ash tray and lighter will come on as well.

3 - Brilliance of instrument, clock, heater control panel light and parking light telltale can be dimmed by rotating the knob.

4 - Beam and dipped lights

Turn the knob forward to the second notch. The movement of the lever back and forth allows the light to be dipped or returned to beam. When the beam lights are switched the blue warning light on facia panel comes on. The lights are extinguished by turning the knob back over the notches.

5 - DIRECTION INDICATORS

Directions indicators are controlled by the light switch lever. Move the lever:

- up, to signal a right turn;
- down, to signal a left turn.

The warning light on facia panel will flash on-and-off. The indicators operate only when the ignition key is in "MAR" position.

6 - HORN

To operate the horn pull the lever toward the steering wheel.

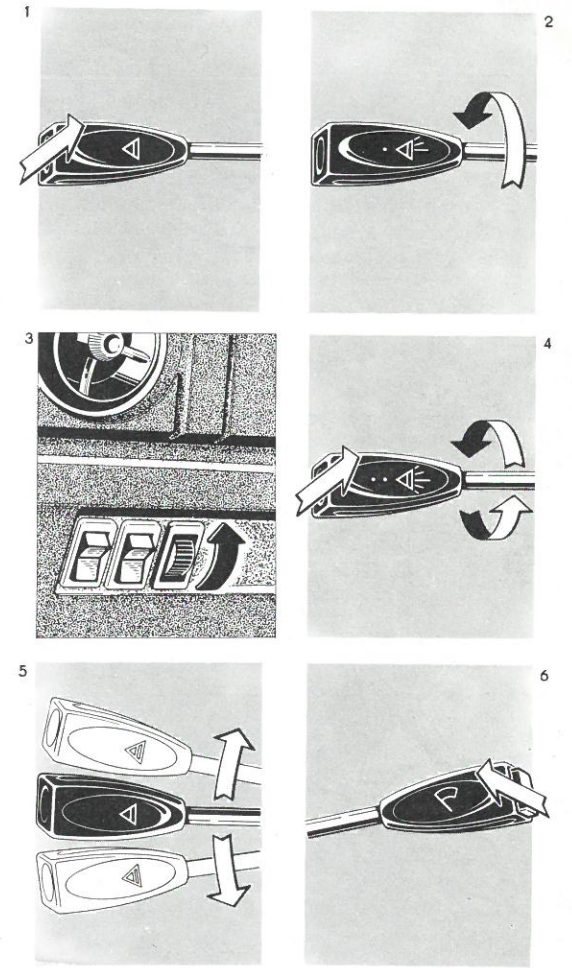

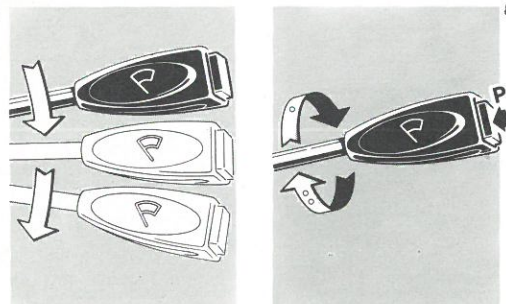

8-9

7 - BLOWER - DEMISTER

It has two speeds:

- with the lever up the blower is off;
- with the lever at the centre or down, the blower operates at normal or high speed respectively, provided the ignition key is in "MAR" position.

8 - SCREEN WIPER

To actuate the two speed wiper: from the off position rotate the lever knob to either of two notches for normal or high wiper speed. The wipers operate only when the ignition key is in "MAR" position.

9 - ELECTRIC SCREEN WASHER

To operate the electrical screen washer, push the button **P** shown at left.



GEARSHIFT LEVER

The gear shifting diagram is shown at left.

When shifting gears, take care to depress the clutch pedal fully.

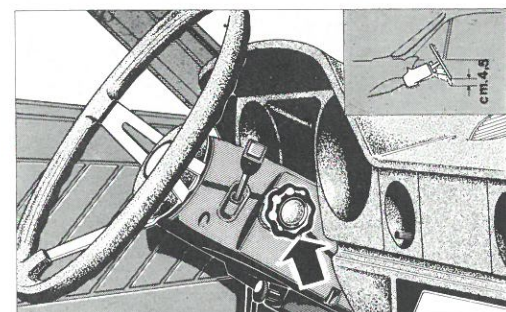

ADJUSTING THE STEERING WHEEL

The adjustable steering wheel can be set in a position to suit your preference. The adjustable range is about 45 mm. Position changes can be made as follows:

- unlock the wheel by unscrewing the knob;
- move the steering wheel to the desired position;
- lock in place the wheel by re-tightening the knob.

PRECAUTIONS

STARTING THE ENGINE

It is advisable, in order to facilitate starting, to press the clutch pedal down fully while at the same time depressing the accelerator pedal slightly.

As soon as the engine fires release the ignition key.

If the engine fails to start at once, operate the choke (about one third of its travel) and try again.

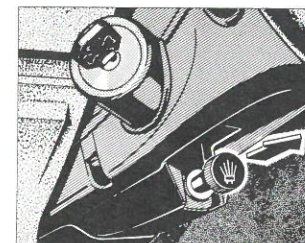

If it still will not start, look for the cause as follows:

- the battery charge may be too weak;
- the battery terminals may be oxidized;
- the ignition equipment may be defective (dirty plugs, oxidized contact-breaker points, wet or cracked distributor cap, damaged distributor or coil);
- the carburettor may be dirty;
- electric circuits may be broken.

When the engine has started move choke knob back in a gradual way; fully press in choke as soon as possible.

Important note: on engaging the choke a warning light (26, page 5) on facia will come on. This light will also alert you if the level in the brake fluid reservoirs falls below the minimum. Check that the warning light lights up when the choke is operated: if not, inspect the bulb. The warning light should go off when choke control is in off position.

Check the coolant temperature warning light (27, page 5). When cold, this warning light stays on until the engine has warmed up to about 45 °C. **Maximum performance must never be demanded of the car before this warning light has gone off.**

Make sure the coolant temperature warning light comes on with cold engine; if not, have the light and/or the relevant circuit and components checked immediately.

Do not accelerate the engine until it has warmed up, since when the engine is cold the oil cannot reach all points requiring lubrication.

Make sure the alternator warning light (25, page 5) goes off as soon as engine speed exceeds idling.

Make sure the oil pressure warning light (24, page 5) goes off as soon as engine is started.

FROM COLD with very low ambient temperatures

To facilitate starting with ambient temperatures lower than 10 °C (12 °F) depress the clutch pedal and pull all the way out the choke knob without depressing the accelerator. When the engine has started, move choke knob back gradually until the coolant temperature warning light goes off; then, push the choke knob in fully.

HOT ENGINE

In summer, or when the engine is already hot, do not use the choke; moreover starting will be facilitated if the accelerator is depressed about half way.

WHILE DRIVING

Check the choke-brake fluid level warning light; if the light comes on **when choke control is in off position**, it means that the brake system is developing trouble. In this case, stop the car and check the brake fluid level in the reservoirs; if the level is too low (refer to page 32) have the brake system checked immediately.

Check the coolant temperature warning light (27, page 5). Should the warning light come on while running with the engine hot, it is an indication of a trouble in the cooling system (engine overheating).

In this case, stop the car and have the cooling system checked by an authorized Service Station.

Take care not to run the engine beyond the maximum R.P.M. shown on tachometer dial with a red area; also do not keep it running for too long a period beyond 6000 R.P.M. (yellow warning area).

Check the oil pressure gauge from time to time and stop the engine if the pressure should fall below limits shown:

Oil pressures with hot engine	
Engine idling	minimum 5
Engine running fast	minimum 35 maximum 45 - 50

Furthermore, check the oil pressure warning light: it is possible for this warning light to blink when the car is cornering; this may be caused by a low level of oil in the sump which can be easily remedied by topping up.

Note: unless oil level has been topped up, the car should be driven at low speed.

Warning: if the warning light stays light continuously, it is an indication of a trouble in the lubricating system: in this case, stop the engine and get the lubricating system checked by an Authorized Workshop.

With the engine stopped and the ignition key in "MAR" position (ignition "on") this warning light may remain lit since in such a condition there is no pressure in the lubricating system.

Do not drive at high speed until the oil in the engine and in the gearbox/differential unit has warmed up properly.





Do not coast downhill with the engine stopped; there will be no suction in the brake vacuum servo and a greater pressure will be needed with the brake pedal to obtain comparable braking effect.

WHILE PARKING

Never leave the key in the "MAR" position (ignition "on") to prevent battery discharge and coil damage. Never remove header tank cap (see page 29) with a hot engine but wait that the liquid is cooled down to ambient temperature.

WINTER PRECAUTIONS

In places where the temperature falls below freezing point, a suitable antifreeze must be added to the engine cooling water to prevent the water in the radiator and in the engine from freezing during prolonged stops.

Recommended products			
 ALFA ROMEO antifreeze std. no. 3681.69956	 F1 Antifreeze	 Antifreeze	 Antifreeze

Quantities of antifreeze to be used depending on the lowest anticipated temperature			
°C	-15	-25	-40
Litres	2.2	3	4

For maintenance hints relating to the cooling system, refer to page 29.

TYRE CHAINS

Tyre chains, to be fitted to drive wheels, should provide enough clearance to prevent possible fender interferences (max. overall tyre size: 16 mm larger each side than tyre cross section).

RUNNING-IN

The car can be driven with no special precaution just from the first trip; however, the following suggestions should be born in mind during the first 1500 - 2000 km to allow the various parts of the car, particularly the engine and the gearbox/differential unit, to settle in gradually.

Starting from cold

- press in choke as soon as possible;
- before driving, run engine at idle for a few minutes.

While driving

- never fully depress the accelerator pedal;
- avoid arriving at the speed limits shown on tachometer for each gear;
- now and then release the accelerator pedal;
- avoid full and extended braking whenever possible.

STOPPING DISTANCE

The diagram shows stopping distance for various speeds based on ideal conditions, i.e. flat, dry, asphalt roads, good tyres, well adjusted brakes and loads properly distributed over the car.

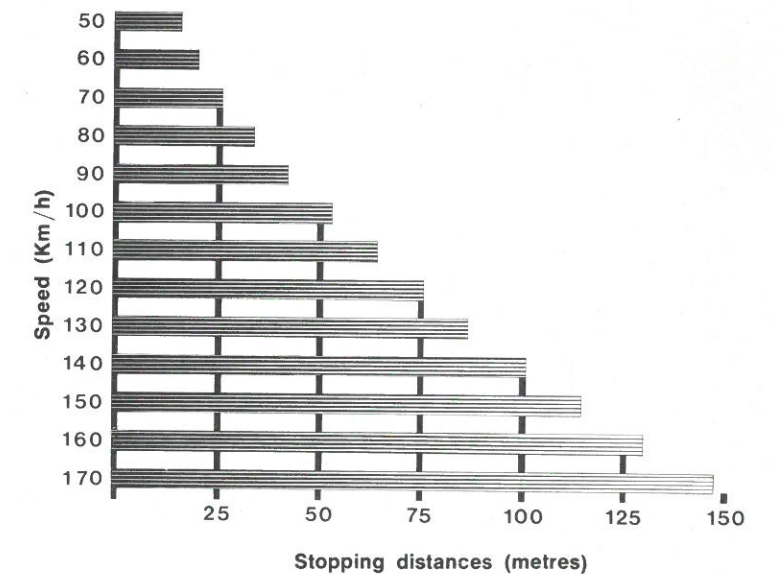

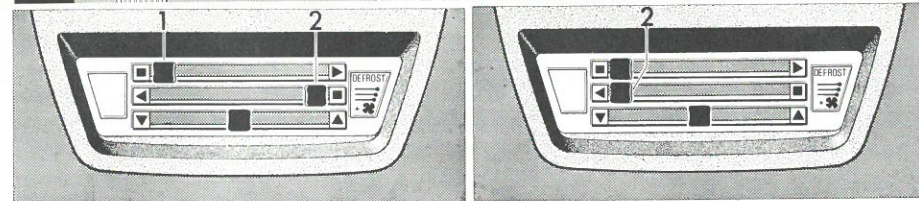
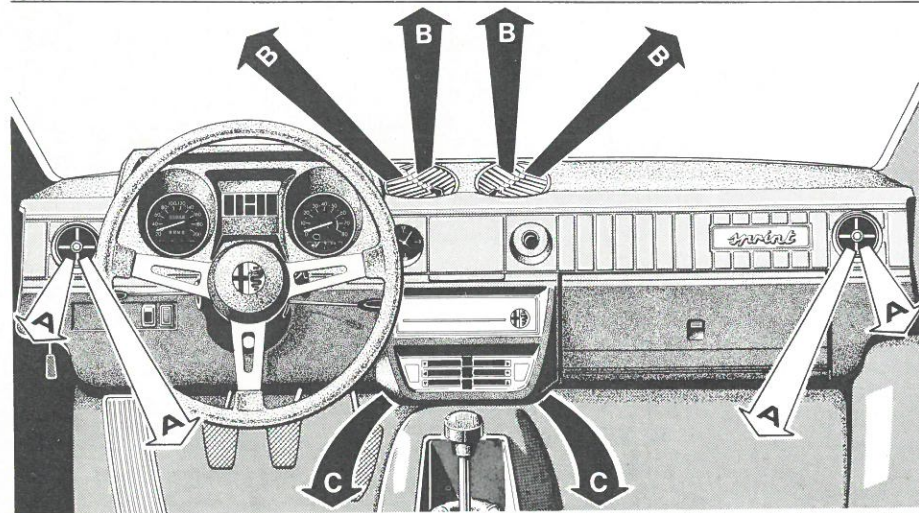

Heat & vent system closed

Fresh air

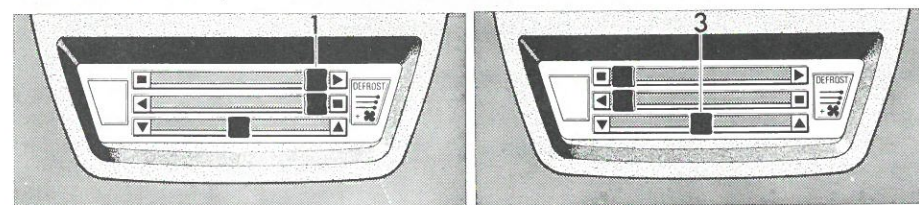

Warm air

▼ Air flowing out of C
▲ Air flowing out of B ▲

VENTILATION-DEMISTING AND HEATING

The air can be admitted to the car both through the ram ventilation outlets **A** and vents **B**, **C** which also provide heating and demisting.

AIR FLOW CONTROL

The vents **A** at the fascia sides enable to direct the flow of ram air as desired. The flow of ram air can be regulated by the knob at the centre of the vent. The movement of the lever **2** regulates the flow of air through the openings **B** and **C**.

Lever at right: shut.
Lever at left: open.

The air admitted to the car interior through **B** and **C** can be heated by the movement of the lever **1** which gradually increases the temperature of the air from a minimum (at left) to a maximum (at right). Operate this lever only when engine is warmed up.

According to its position, the lever **3** regulates the flow of air between the heater **C** and the demister **B**:

- ▼ air flowing out of openings **C**
- ▲ air flowing out of demister openings **B**

WARM AND FRESH AIR BLENDING

The air temperature can be adjusted by operating both the ventilation and temperature levers **1** & **2** as shown at the illustration.

TWO-SPEED ELECTRIC BLOWER

In order to produce a satisfactory flow of air into the car at low speeds, switch on the blower with the lever **7** shown at page 8. Blower speed increases past the first click.

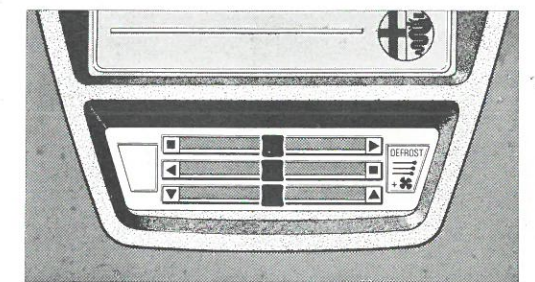

Blend position

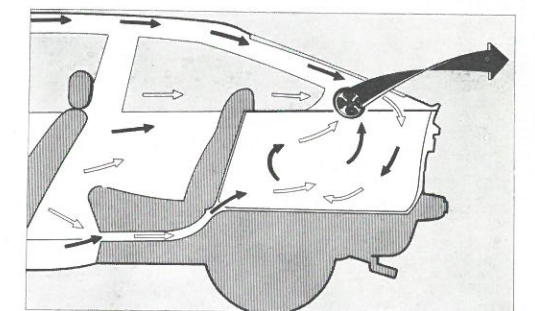

AIR DISCHARGE

For a best ventilation, air discharge passages are provided at rear seats and through the backshelf. Then, air flows out through discharge openings in rear posts.

HEATED REAR WINDOW

The car is provided with an electrically-heated rear window. When switched on, the electric resistance embedded in the glass will demist it. The warning light built into the switch button indicates that the heated rear window is on.

Caution

Switching on the heated window when the engine is stopped should be avoided to prevent discharging the battery. It is also advisable to switch off the heated window as soon as defogged.

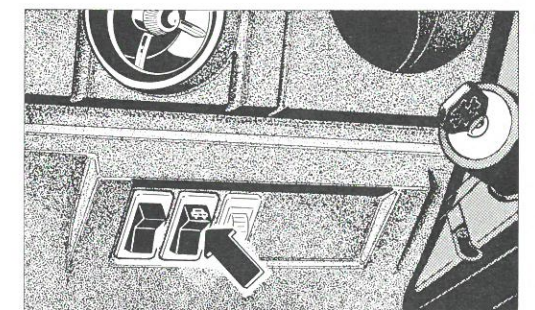

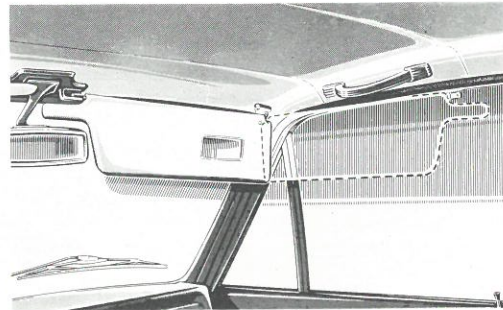

INTERIOR

SUN VISORS

The front seats are equipped with padded sun visors. The passenger's visor is provided with a vanity mirror. The driver's visor has a pocket for documents.

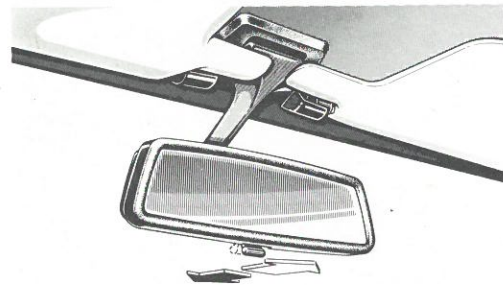

REARVIEW MIRROR

The rearview mirror has a day/night anti-dazzle device. The rearview mirror snaps off automatically in the event of a crash.

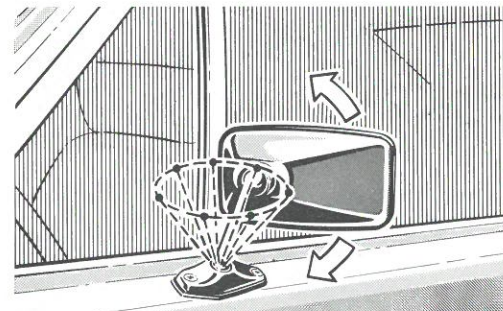

Two ball joints enable the door mirror to be positioned as desired.

CIGARETTE LIGHTER

Push the knob in; this brings into operation an electric element which enables to light the cigarette.

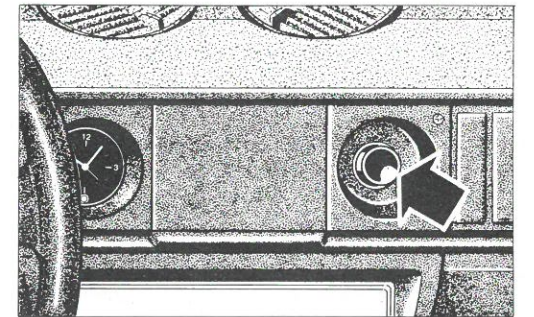

COURTESY LIGHTS

The light unit is in the centre pillar at driver's side.

The switch has three positions:

- one in the centre: lights always off;
- two at the sides: lights always on or automatically operated when opening doors.

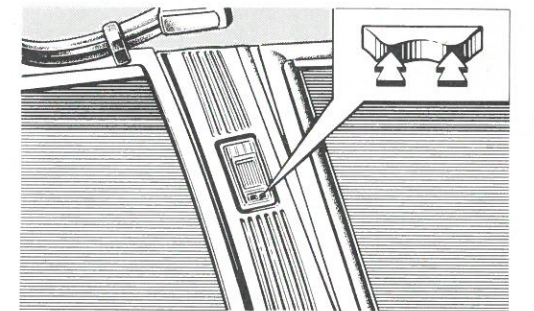

GLOVE COMPARTMENT

To open, push the knob on the lid upward.

When parking lights are lit, on opening the lid a light will come on.

ASH TRAYS

The ash tray for front seats is at the centre of facia panel.

When parking lights are lit, a light comes on as an aid in locating the tray. The front ash tray can be removed for emptying by pressing down the small metal spring.

The ash tray for rear seats is located on central console; to remove the ash tray, pull it upward.

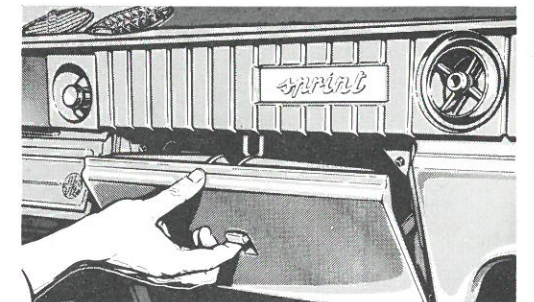

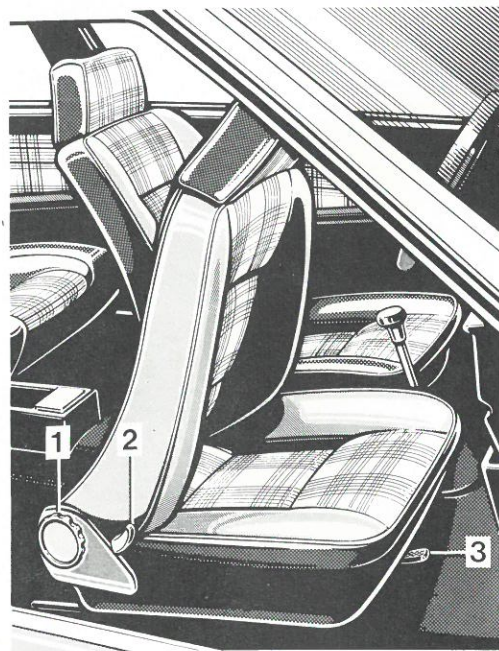

FRONT SEATS

The positioning of the front seats is controlled by the lever 3 shown at left; by freeing the lever the seat can be locked to the position desired.

Two knobs 1 at the outboard sides of the seats control the angle of the backrests. To facilitate access of passengers to the rear seat, the backrest may be tipped forward by releasing the lever 2.

The front seats have vertically adjustable head restraints.

SAFETY BELTS

Provision is made for the fitting of safety belts to front and rear seats. The reinforced attachment points are located (see illustration):

Front seats

A: at the upper part of centre pillars

B: at the bottom of centre pillars

C: between seats

Belt installation can be by points A and C for shoulder belts, points B and C for lap belts and all three points for lap and diagonal harness.

Rear seats

D: at the upper part of rear pillars

E: at rear wheelarches

F, G: at rear part of floor.

For the two passengers at the sides shoulder belts can be installed by points D and G, lap belts by points E and G and lap & diagonal harness by all three attachment points; for the central seat (3rd passenger) a lap belt can be installed (by attachments F).

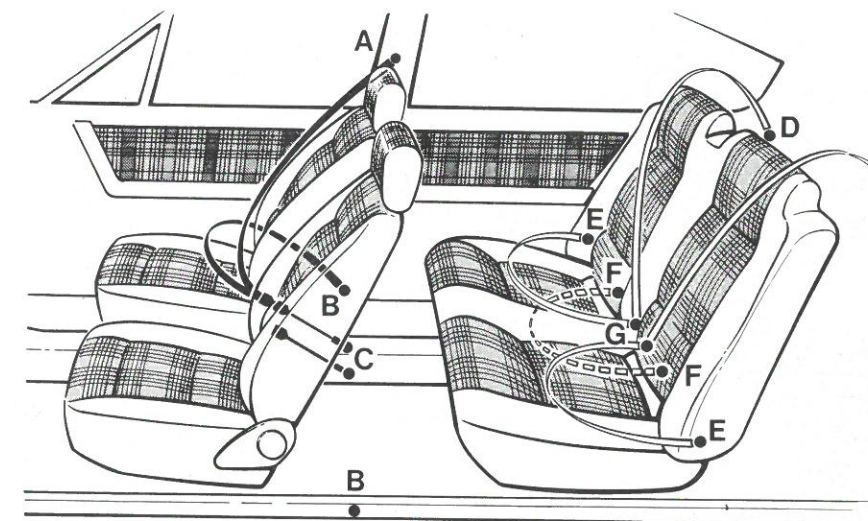

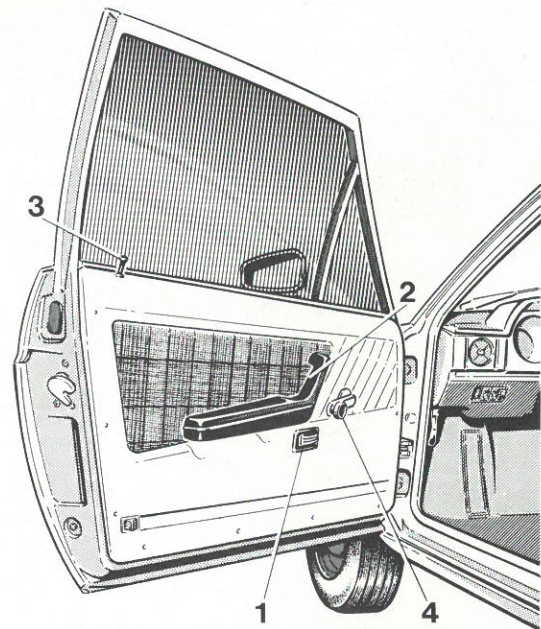

DOORS AND WINDOWS

To open the doors from the outside (when unlocked), push the button in the handle.
 To open the door from inside, pull the lever 1 under the armrest; use grip 2 for pulling the door when closing from inside. For locking the doors from inside, push in the button 3 after the door is shut.
 Both doors have locks for closing from the outside.
 To lift or lowering the window act on the handle 4.

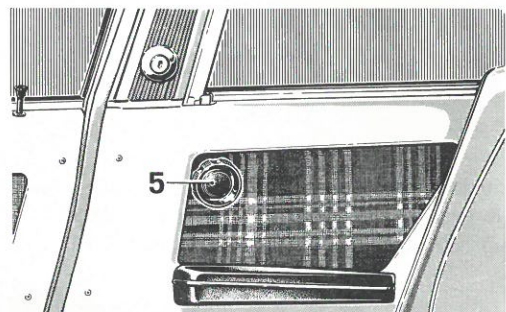

To lower (only partially) or lift the rear quarter windows, rotate the handle 5.

ENGINE BONNET

To release the catch, pull the lever under the fascia panel; raise the bonnet and make certain the support rod engages the stop. When parking lights are on the engine compartment light will come on.
 To close the bonnet move it slightly forward until the support rod disengages from its stop; hold the rod in disengaged position and lower the bonnet until it rests against the catches. To lock the bonnet push the lever toward the front of the car.

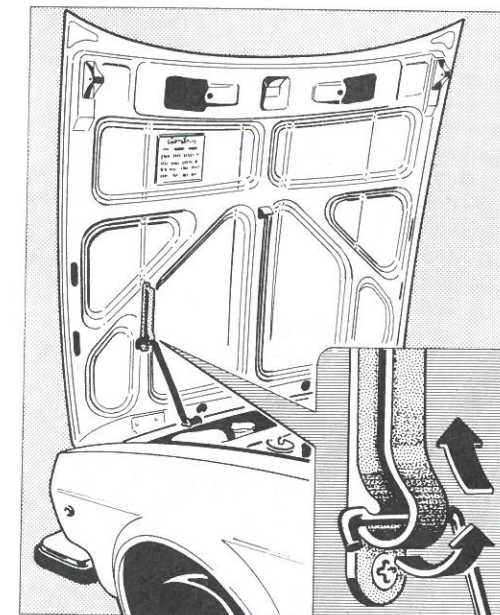
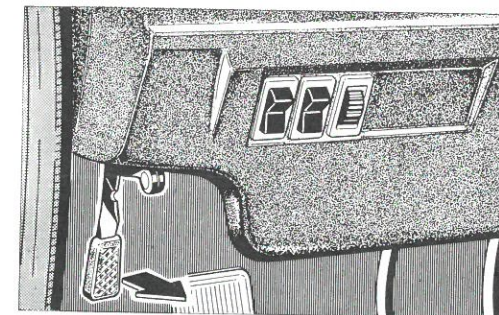

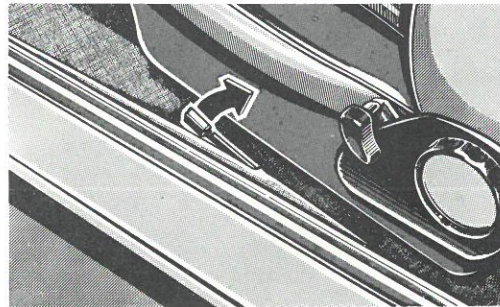

TAILGATE

To release the tailgate pull up the lever at the left side of the driver's seat.

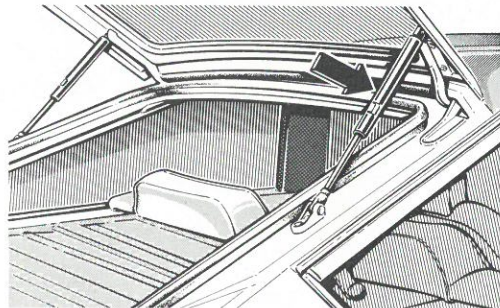

The tailgate encompassing the whole of back window lifts automatically with the gas-filled struts. **Never tamper with the raising strut.**

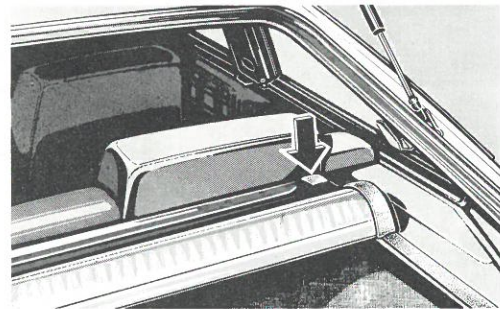

The luggage compartment is covered by a retractable shelf fixed at the sides and at the rear by strips of a special material.
To gain access to the luggage compartment, raise the rear end of shelf and roll it up until it sticks to the blocks at rear seat squab as shown.
Lighting of the luggage compartment is provided by a lamp which lights up when parking lights are on.
To spread down the shelf, unroll it and apply pressure downward to the sides and rear end so as to make them adhere to the strips.
Do not put heavy parcels on the shelf.

In the luggage compartment there are the tool kit and the spare tyre under the mat, the jack and the wheelbrace at the right side.
To remove the jack, release the rubber strap 1 and unscrew the knob 2.

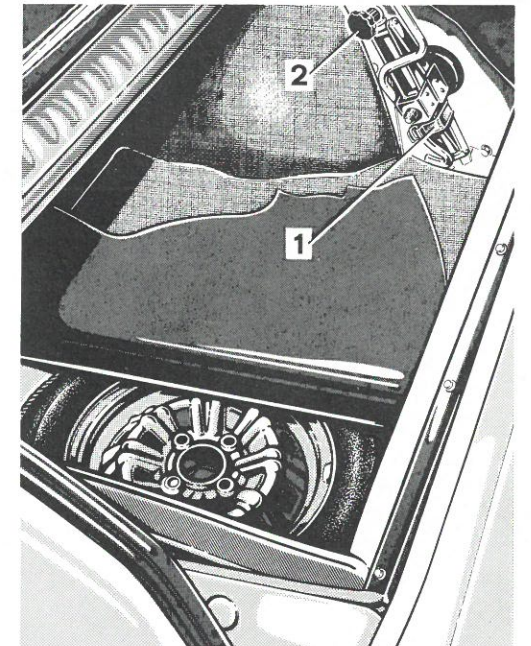

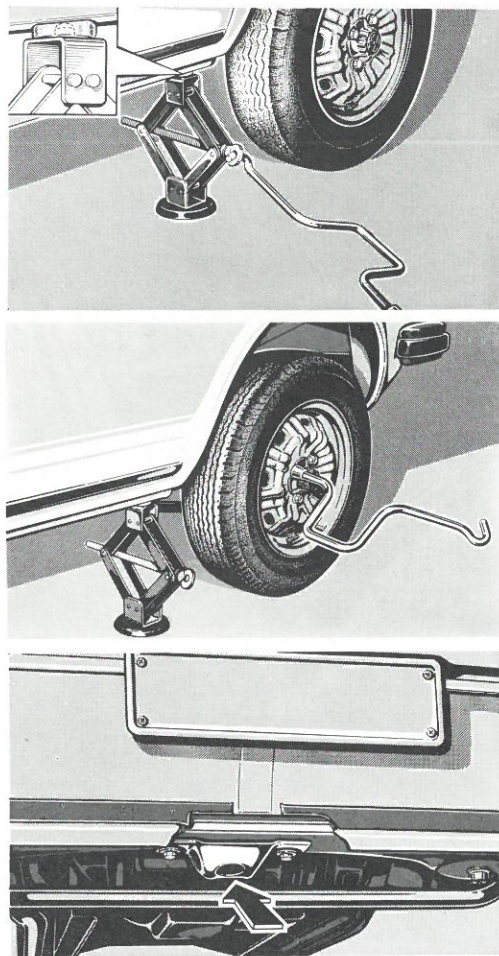

WHEEL CHANGE

Wheel removal

- Apply the handbrake.
- Remove jack and wheelbrace from boot (refer to preceding page).
- Slacken wheel bolts by one turn: turn anti-clockwise to unscrew.
- Raise the car by inserting the jack end in the special socket on the underside of the body.
- Remove the wheel bolts and remove the cover and the wheel.

Reinstallation

- Fit the wheel and the cover by fixing with the screws only hand-tight.
- Tighten the nuts carefully in diagonal order; turn the nuts clockwise to screw in.
- Check again tightness of nuts after lowering the jack.
- Release the handbrake.
- As soon as possible, check that the inflation pressure is as specified (refer to inside backcover).

TOWING

When taking a tow, secure the rope exclusively to the suitable bracket shown in the illustration.

When towing another vehicle, secure the cable to the back axle right side making certain not to damage the pipe of hydraulic brakes and the link of the brake pressure regulator.

LUBRICATION

Tick each item at the respective kilometres

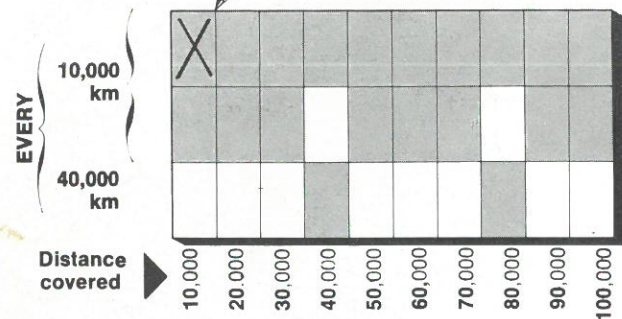

LUBRICATION SCHEDULE

At the first 1300/1700 km Have the free **Coupon** from the Service Coupon Book carried out.

Change engine oil and filter (or every 6 months whichever comes first).

Check level of gearbox/differential oil and top up if necessary.

Change gearbox/differential oil.

Occasionally
Check level of engine oil and top up if necessary.

The lubricants used for the first filling, shown by the plate in the engine compartment and the table "Recommended lubricants" on inside backcover, are factory tested for meeting completely the operation requirements. These lubricants can be used both for topping up and changing (when topping up it is recommended to use exclusively the same type of oil as already filled in the engine or main unit). In countries where the above mentioned lubricants are not available, and when absolutely necessary, it is possible to replace them with products of other leading makes provided that in accordance with the grades given in the table; in such a case, however, it is essential to renew all the lubricant in the circuit.

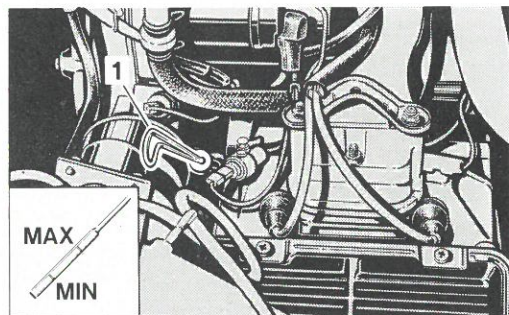

OIL LEVEL CHECKING

Withdraw the dipstick 1 and clean it; then, push the dipstick all the way down into its housing to check whether oil level falls within MIN. and MAX. marks.

OIL CHANGE

At the prescribed mileage intervals (or every six months whichever occurs first), change oil in the sump (engine warmed up) by proceeding as follows:

- With the engine stopped, drain off old oil thoroughly by removing the oil filler plug 2 the dipstick 1 and the drain plug 3.
- Renew the oil filter (see below).
- Clean drain plug 3 and refit it.
- Refill with new oil and refit the filler plug 2.
- Clean the dipstick 1, insert it to check that oil level does not exceed the "MAX" mark. Push dipstick all the way home.

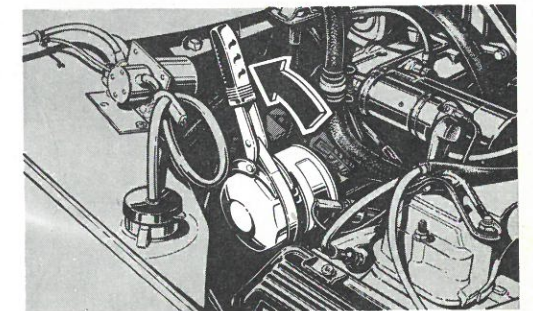
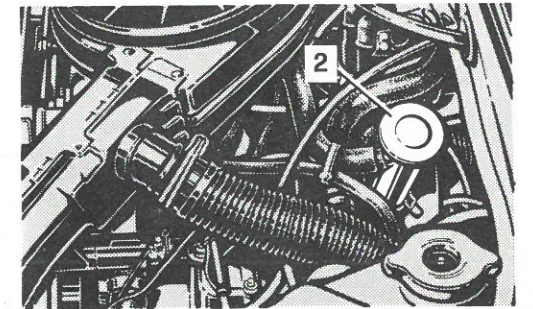

RENEWING THE OIL FILTER

Slacken the filter with the suitable spanner, then remove the filter. Start the new filter by hand, then tighten it securely to prevent oil leaks.

CHECKING AND CHANGING GEARBOX/DIFFERENTIAL OIL

To check gearbox/differential oil level at the prescribed intervals, remove filler plug 4; oil level should be at the edge of filler orifice.

To change oil proceed as follows (when hot):

- Drain off old oil by removing drain plug 5 and filler plug 4;
- Clean drain plug 5 and refit it;
- Replenish with oil of the prescribed type (refer to inside backcover) through filler plug 4. Check that oil level is at the edge of filler orifice; clean filler plug and fit it.

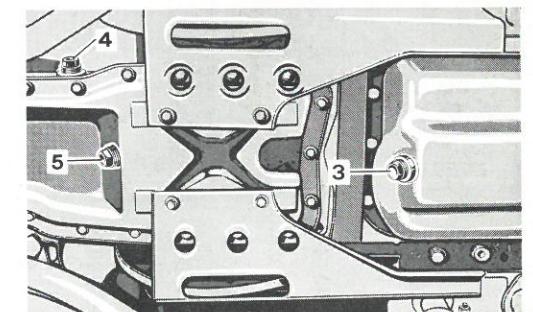

INSPECTION - ADJUSTMENT

Tick each item at the respective kilometres

	At the first 1300/1700 km									
EVERY 10,000 km	<input checked="" type="checkbox"/>									
EVERY 20,000 km										
EVERY 40,000 km										
EVERY 60,000 km										
Distance covered	10,000	20,000	30,000	40,000	50,000	60,000	70,000	80,000	90,000	100,000

MAINTENANCE SCHEDULE

Have the free Coupon from the Service Coupon book carried out
Check spark plugs for wear and clean them if necessary
Clean air filter element and change it, if necessary
Check bellows of constant velocity joints for soundness
Check battery electrolyte level and top up if necessary (more frequently in summer months); also check terminals for proper tightness and lubrication
Check tyre inflation pressures and front brake pads for wear
Check level of fluid in brake and clutch reservoir
Check idle speed and exhaust emissions; adjust, if necessary
Check feed system, cooling circuit and heating system for leakage
Check valve clearance and adjust, if necessary
Check the air intake temperature control system
Check tension of alternator and water pump driving belt; adjust, if necessary
Check contact-breaker point gap. Check ignition timing; adjust, if necessary *
Clean crankcase ventilation system and change fuel filter
Check door and lid hinges and locks for operation and lubrication
Check brake system; check rear brake pads for wear
Test vehicle
Clean carburettor
Change brake fluid-or once a year whichever comes first
Check front wheel toe-out and adjust, if necessary
Change alternator and water pump driving belt. Change camshaft driving belts
Occasionally
Check level of coolant in engine cooling system reservoir.

AIR FILTER

Air intake temperature control device

This device is designed to maintain the intake air entering the engine at a constant temperature. This is obtained by means of a thermostat in the air cleaner controlling the position of the valve which in turn controls the amount of hot and cold air entering the air mixer tube. At the prescribed periods have this device checked for proper operation.

Cleaning the filter element

- Unscrew the wingnut securing the filter cover.
- Remove the cover and withdraw the element.
- Clean it carefully from inside with low-pressure compressed air. Change the element, if necessary.

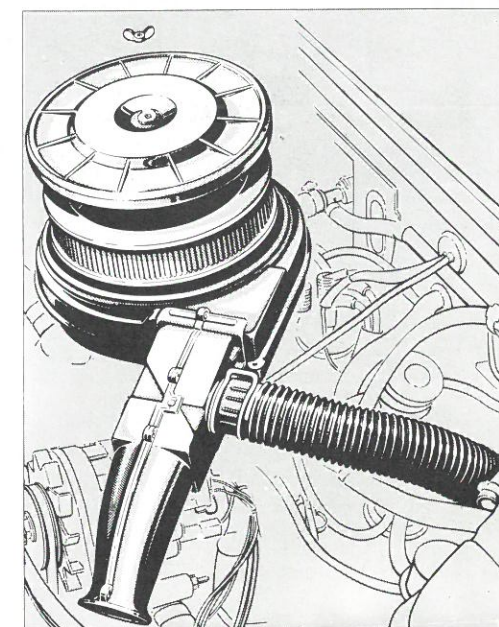

ALTERNATOR AND WATER PUMP DRIVE BELT

The tension is correct when, on pressing the belt down with a load of about 8 kg, the amount of play is approximately 1/2 in. (15 mm). To tighten the belt unscrew the nuts 1 and 3 on the adjusting bracket and bolt 2. Move the alternator upwards to increase belt tension and retighten nut 1; re-check the belt tension. Tighten bolt 2 and nuts 3.

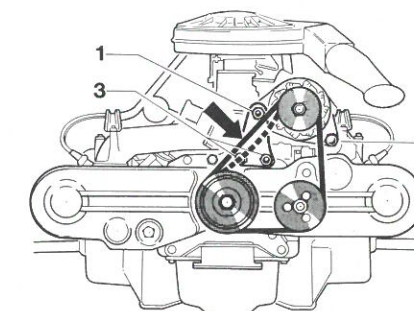

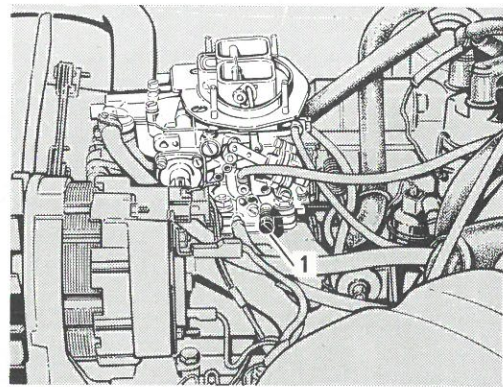

Weber 32 DIR 61/250 Carburettor

CARBURETTOR

At the prescribed intervals clean the carburettor and change the fuel filter.

Important note

Since the fuel feed system of this car is manufactured to meet the EEC 74/290 antipollution standards, the idle speed and metering of mixture (and consequently the relevant adjusting screws) are factory set. Such a set must in no way be altered. If the idle speed and the CO percentage in the exhaust gases should not be as specified (800/900 r.p.m. and 1.5-2% in volume respectively) adjust by turning the adjusting screw 1 only.

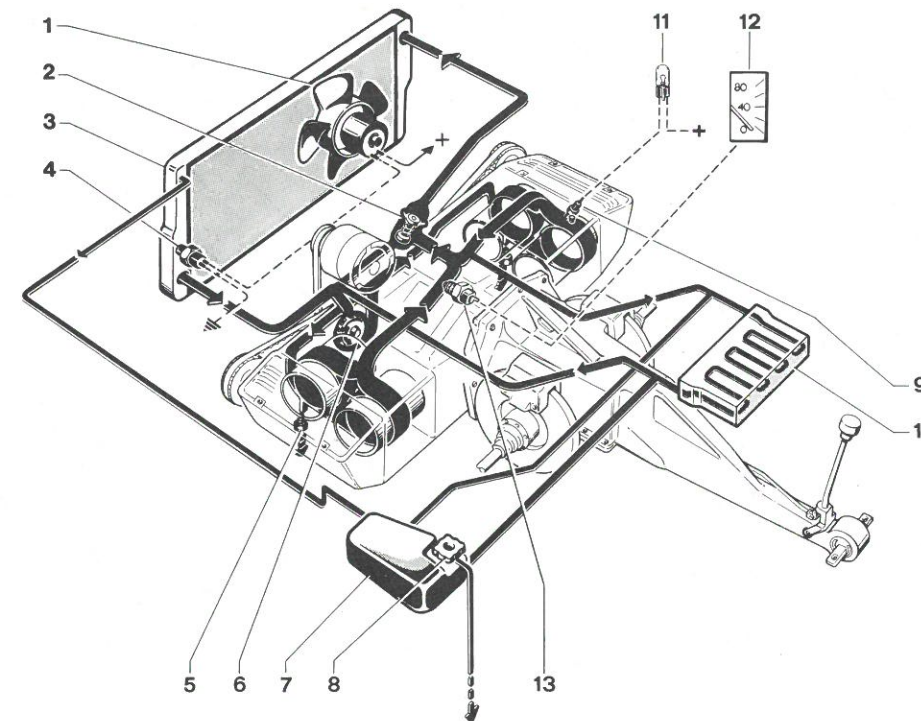

COOLING SYSTEM

- 1 Electric fan
- 2 Thermostatic valve
- 3 Radiator
- 4 Electric fan thermostatic switch
- 5 Drain plug (one for each bank of cylinders)
- 6 Pump
- 7 Header tank
- 8 Cap with calibrated valve
- 9 Thermostatic switch for coolant temperature warning light
- 10 Heater
- 11 Coolant temperature warning light
- 12 Coolant thermometer
- 13 Coolant thermometer sender

The sealed type cooling circuit is provided with a header tank.

The coolant, kept in circulation by the pump 6, cools down the cylinder heads and sleeves then flows, through return lines, to the thermostatic valve 2.

Hence, according to the position of the valve spool, the coolant is sucked by the pump either from the thermostatic valve or the radiator outlet line.

The electric fan 1 automatically cuts in by means of the relay in turn energized by the switch 4, when coolant reaches a temperature of 88-92 °C.

Occasionally, check level of coolant in the tank: this should be done **exclusively with a cold engine** as with a hot engine the level may increase remarkably. The level of mixture in the reservoir should **never** fall below the minimum (level 1) nor exceed the maximum level (reference mark 2).

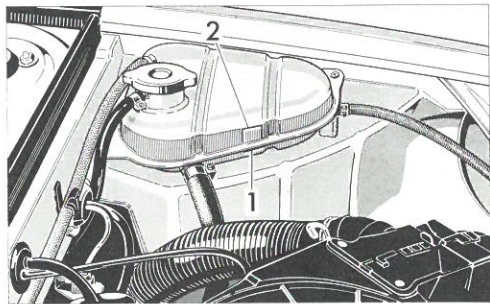

Should an excessive coolant consumption be experienced, have the cooling system hoses checked for no sign of leaks. Check the tank cap to make sure that the spring, the seal and the valves are operating properly. If necessary, replace the cap with a genuine spare part; soak the seal on installation.

DRAINING AND REPLENISHING THE SYSTEM (refer to the illustration on page 29)

- Remove cap 8 from tank.
- Remove drain plugs 5 (one for each bank of cylinders) and let liquid drain off.
- Reinstall drain plugs.
- Pour coolant mixture through tank filler port until coolant reaches the bottom edge of the filler port itself.
- Start the engine and warm it up until the electric fan cuts in; this indicates that the thermostatic valve has opened.
- Allow the engine to cool down, check again coolant level and replenish, if necessary.
- Refit tank cap.

BRAKE SYSTEM

- 1 Brake pads, front
- 2 Piston
- 3 Bleed screw, front circuit
- 4 Inboard piston operating levers (handbrake)
- 5 Handbrake cable
- 6 Emergency and handbrake lever
- 7 Brake disc
- 8 Piston, rear brakes
- 9 Brake pads, rear
- 10 Bleed screw, rear circuit
- 11 Stop lamp
- 12 Brake pressure regulator spring
- 13 Brake pressure regulator
- 14 Preloading mechanism for brake pressure regulator spring
- 15 Booster cylinder/servo unit
- 16 Brake and clutch fluid reservoir
- 17 Low fluid level warning device
- 18 Brake pedal
- 19 Stop lamp switch
- 20 Warning light for choke and low level of clutch & brake fluid

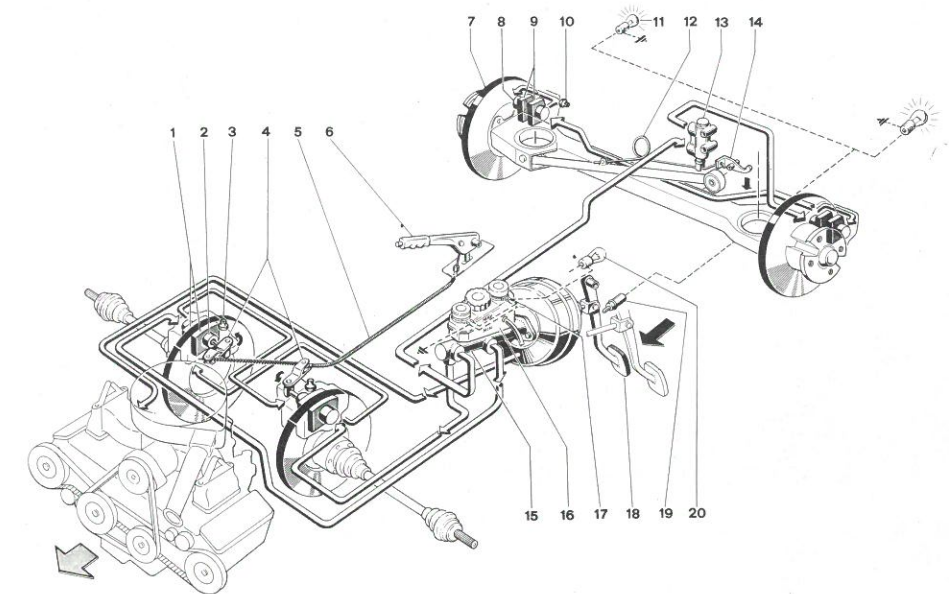

Two switches at the top of fluid reservoirs on brake master cylinder (15) light up the low fluid level warning light. This light serves also as a warning for the operation of the choke. Therefore, should the warning light come on, first be sure the choke control is in off position. If, with choke control off, the warning light still remains lit, stop the car and check the fluid level in the reservoirs (refer to the following page).

HANDBRAKE

The mechanically operated handbrake is correctly adjusted when the wheels become locked as the lever is drawn through one to three notches.

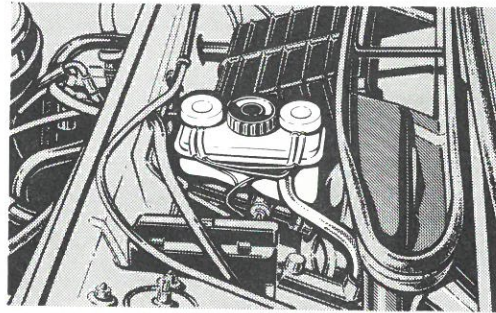

CLUTCH AND BRAKE FLUID RESERVOIR

Care should be taken to prevent the level of fluid in the reservoir from falling below the maximum level by more than a quarter. Renew the fluid at the prescribed periods. For renewal or topping up, it is absolutely essential to use only the specified fluid drawn from freshly opened sealed containers. When adding fluid, leave the strainer in place so as to filter the fluid.

Warning - For effective and reliable operation of the brake system, the pipes must always be full of fluid and free of air bubbles. **Excessive and spongy brake pedal action is an indication of the presence of air bubbles in the system.**

Clutch and disc brake fluid		ALFA ROMEO std no. 3681.69903
		F1 BRAKE FLUID Super HD
		« BLAU S »

CLEANING INSTRUCTIONS

Flushing the circuit

Should flushing of the brake circuit be required, use exclusively fluid of the specified type.

Caution - Compressed air or alcohol must on no account be used to dry a flushed system.

Cleaning the outside

To clean the outside of brake assemblies use suitable detergents mixed with hot water; then thoroughly dry all components with compressed air. Never use gasoline, trichloroethylene or similar solvents. While servicing the car, be careful not to let lubricants come in contact with the discs and friction pads. When cleaning the car, it is advisable to mask off the brakes to avoid damaging the brake components.

Important warning - In case of accident or damage to the chassis check that the brake vacuum servo is undamaged, since even slight superficial body damage may seriously impair the functioning of the brakes.

WHEELS

TYRES

For inflation pressures refer to inside backcover.

- 1) **Correct**
The tyre gives optimum performance, the tread works over its entire width, thus ensuring uniform tyre wear and long life.
- 2) **Too low**
The tyre will overheat, the sides of the tread will wear quickly and the tyre plies will tend to separate.
- 3) **Too high**
Riding comfort will be reduced, and the tyre will suffer from excessive wear in the centre of the tread and vulnerability to knocks.

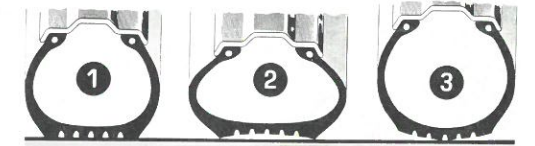

CHANGING OVER

To ensure even and uniform tyre wear and long tyre life, front and rear wheels and the spare should be changed over regularly and accordingly to the diagram shown. After changing over inflate tyres as specified; refer to inside backcover.

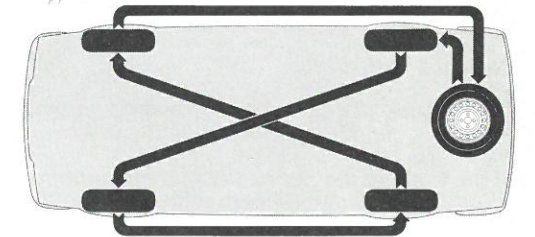

BALANCING

Each wheel, complete with its tyre, is statically and dynamically balanced at the factory. Whenever a tyre is changed, the wheel must be rebalanced. It should be remembered that unbalanced wheels cause unstable steering, abnormal steering gear wear and uneven tyre wear.

BODY MAINTENANCE

CHANGING SCREEN WIPER BLADES

Push locking lever up and withdraw the wiper blade. To refit the wiper blade position it on the wiper arm and push in until locking pin engages.

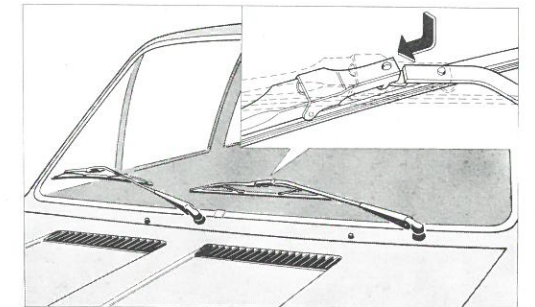

SCREEN WASHER LIQUID

Occasionally, check level of liquid in screen washer container and replenish if necessary. If run out of liquid, do not persist in operating the screen washer or the electric pump will be damaged.

On inspecting or topping up, care should be taken not to disconnect the pump tube.

In winter, never add water only.

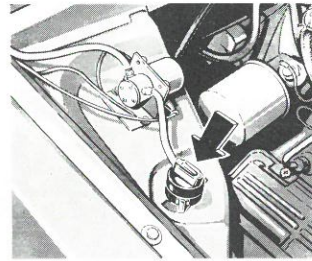

WASHING THE CAR

The body should be washed frequently, depending on the use of the car, the environmental conditions and the state of the roads.

Avoid washing the car in the sun and proceed as follows:

- first flush the car all over with jets of water to remove the dust;
- prepare a solution of suitable detergent in water (0,2% in weight);
- with the solution and a sponge wipe down the whole body;
- rinse thoroughly with plenty of water;
- dry with compressed air, if possible, then with chamois leather.

Grease, oil and tar stains may be removed from the paintwork by applying petrol to the stained area, and then rubbing it with a dry cloth.

POLISHING

To put fresh gloss on the paintwork, polish once or twice a year with a suitable polish.

Do not use petrol or solvents on rubber mouldings and weatherstrips. When refuelling or lubricating, be careful not to splash petrol or brake fluid on the paintwork.

CLEANING THE WINDOWS

Use only a very soft cloth or chamois leather for cleaning the windscreen and windows. If the panes are very dirty, use windscreen washer fluid or water mixed with alcohol.

When cleaning the inside of heated rear screen, great care should be taken not to damage the electric resistance wires on screen surface.

UPHOLSTERY

Periodically dust the inside upholstery using a vacuum cleaner if possible.

To remove oil and grease stains, use diluted ammonia on the cloth parts and neutral soap on the leatherette.

Use trichloroethylene or neutral soap to remove stains from the carpets.

LAYING THE CAR UP

If the car will be left unused for any length of time the following protective steps should be taken:

- Empty the fuel tank, the fuel pump and the carburettor float chamber;
- clean the fuel filter;
- inject a little engine oil into the cylinders through the spark plug holes and rotate the crankshaft by hand several times in order to spread a film of oil over the cylinder walls;
- remove the battery, store it away from frost, and recharge it once a month; never allow it to become fully discharged or plate sulfation will result;
- jack up the car, clean the tyres and slightly deflate them; if tyres are removed, dust them internally (and their tubes) with talcum powder; store them in a dark and airy but dry place;
- dust the seats and upholstery with moth preventive;
- cover the car with a dust sheet. To avoid serious damage to the paintwork, do not use polyvinyl-type tarpaulins.

ELECTRICAL EQUIPMENT

BATTERY

The battery water level should be more than 3/16" (4.5 mm) above the plates. When filling up the battery, use only distilled water; never add acid. Make sure that terminals are tight and are sufficiently coated with pure vaseline.

Furthermore, the following should be born in mind:

- In summer, check frequently the electrolyte level.
- When recharging the battery, completely disconnect it from the system.
- Never reverse the battery polarity or the alternator diodes will be damaged.
- When electric weldings are carried out on car, disconnect battery making sure the positive terminal is properly insulated. **The engine must be stopped.**

ALTERNATOR

The alternator requires some special cares.

- It should not be tampered with.
- Never disconnect the battery terminal of alternator-to-battery cable while the engine is running.
- Avoid overloading the alternator bearings (refer to page 27 for correct belt tension).
- It is recommended to entrust any inspection or repair work to **Authorized Workshops.**

SPARK PLUGS

The only maintenance required is occasional cleaning with a brush of the central and earth electrodes.

No routine adjustment is necessary of the gap between the electrode and points.

Spark plug make and type are LODGE 2HL.

The spark plugs should be tightened when cold to a torque of 18-25.3 lb-ft (2.5-3.5 kgm); lubricate the threads with graphite grease before fitting.

IGNITION DISTRIBUTOR

At the prescribed intervals check with a feeler gauge the contact-breaker point for proper gap.

To adjust, proceed as follows: remove rotor arm 1, rotate spindle for maximum point gap, loosen the screw 2, insert a screwdriver in the adjustment slot and pry the stationary-point plate back or forth as required; then, retighten the screw.

S = 0.35 - 0.45 mm.

Occasionally, soak the felt 3 with oil.

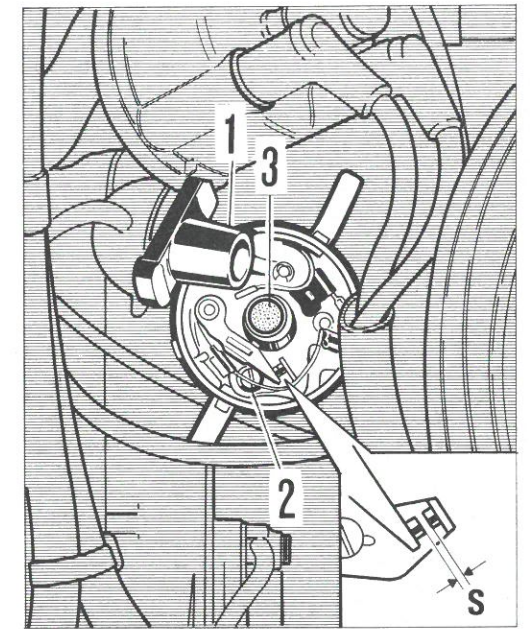

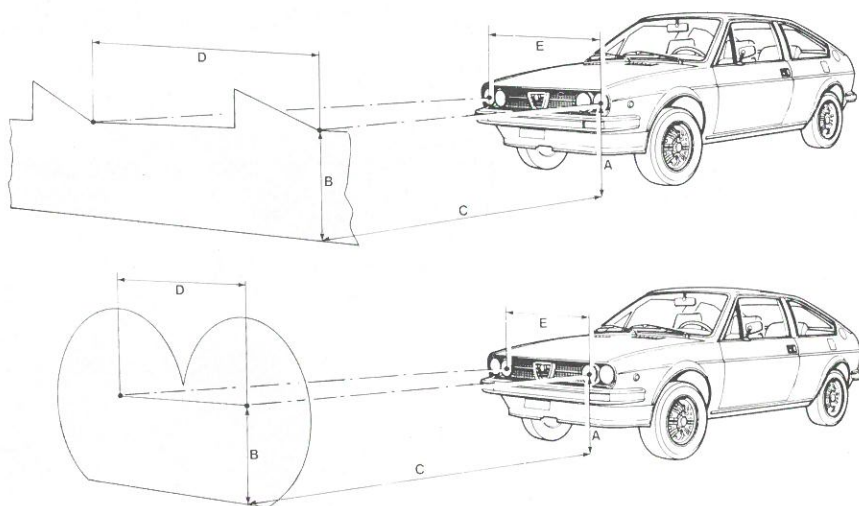

HEADLAMP BEAM SETTING

The pattern shown refers to cars for export to R.H. rule of road countries; for L.H. rule of road, the pattern is exactly opposite, i. e. upper area slanting from left to right.

The headlamp beam setting should be checked against the figures indicated in the diagram, with the car unladen, on a level surface and an absolutely vertical screen.

A = height of headlamp centre
B = height of beam pattern
C = 10 metres = 33 ft.

The setting is correct when the following requirements are met:

Outer headlamps:

B = A — 200 mm (new vehicle or suspension springs renewed).

B = A — 180 mm (suspension settled down, i.e. when vehicle has covered such a distance as stated on free service coupon).

Inner headlamps:

To align the inner high beams mask out the outer lamps.
B = A — 160 mm (new vehicle or suspension springs renewed).
B = A — 140 mm (suspensions settled down, i.e. when vehicle has covered such a distance as stated on free service coupon).
The distance D between centrelines of beam patterns should be the same as that between headlamp centrelines E.

Setting

Should beam setting require correction, act on the adjusting screws.
H - screw for horizontal adjustment
V - screw for vertical adjustment.

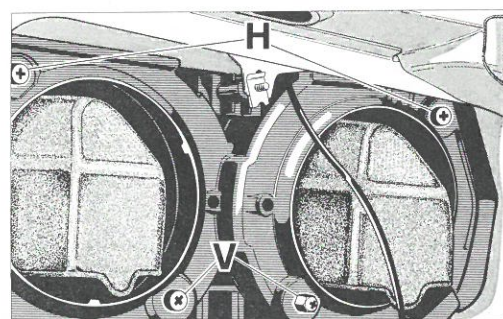

REPLACING BULBS

Note: the bulbs of front direction indicators and parking lights, side direction indicators, tail parking and stop lights, tail direction indicators, reverse light and number plate light have bayonet-type mounts. To remove the bulbs, it is therefore necessary to press the bulb in, rotate it anti-clockwise and then withdraw it.

Headlamps

Take the rubber protection off the headlamp by catching the blades at the bottom, disconnect feed wire 1, release the retainer 2 securing the bulb (by pushing the free end of retainer towards the front of the car) and remove the bulb.

Fit the new bulb to the headlamp (never touch with the fingers the glass of the halogen bulbs; always remove possible fingerprints with alcohol before fitting the bulbs); make sure the locating bosses on bulb socket fit properly into the notches in the headlamp lens unit and secure the bulb in place with the retainer 2.

Fit the feed wire connector to the bulb socket and re-install rubber protection to headlamp.

Front parking lights

The bulb socket fits into the bottom of outer headlamp. To renew the bulb, remove the rubber protection from the headlamp lens unit and withdraw the bulb socket 3. Be careful not to disconnect the earth connector from the headlamp unit.

Refit the bulb socket in such a way that the tongue of the grommet 4 matches properly the lens unit.

Side direction indicators

From inside the wheelarch, remove bulb and socket as a unit 5 from lens 6. Take out the bulb.

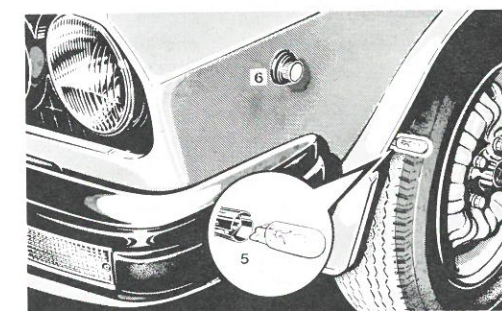
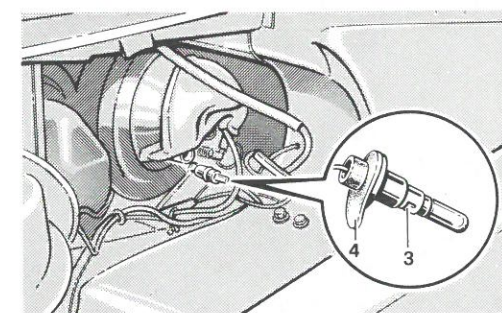
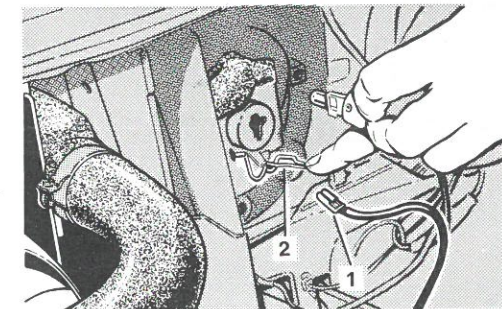

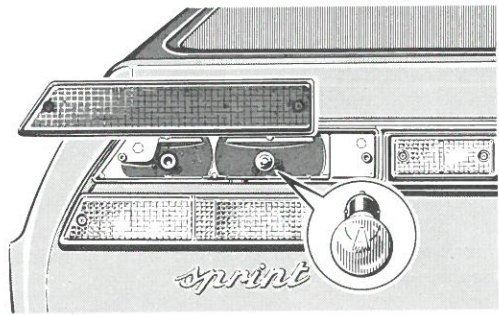
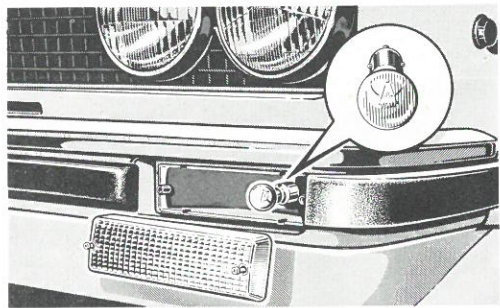

Front direction indicators
Tail direction indicators, reversing, parking and stop lights

Slacken the four attaching screws and remove the lens.
Replace the affected bulb.
Note: attention should be paid not to lose the rubber rings on the attaching screws (at lens inner side). If, on removing the lens, these rings get out of screws, refit them onto the screws.

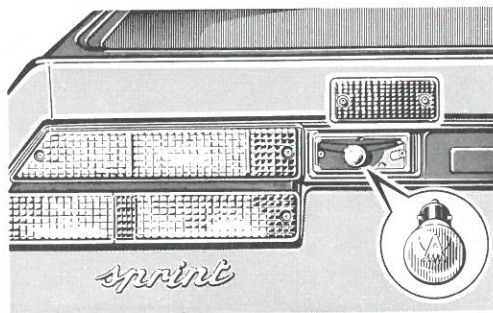
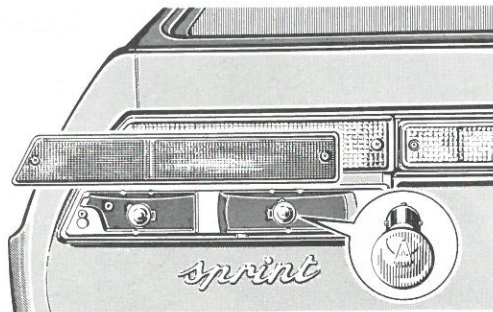

Number plate lights

Slacken the attaching screw and remove the ornament.

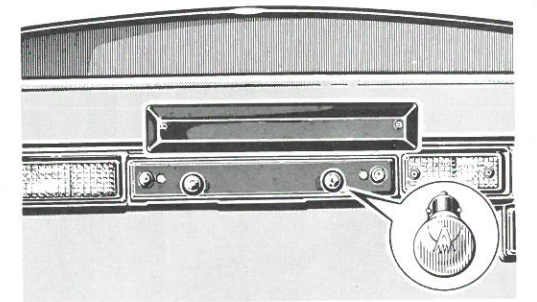

Courtesy light

Snap off the lens; replace the bulb.

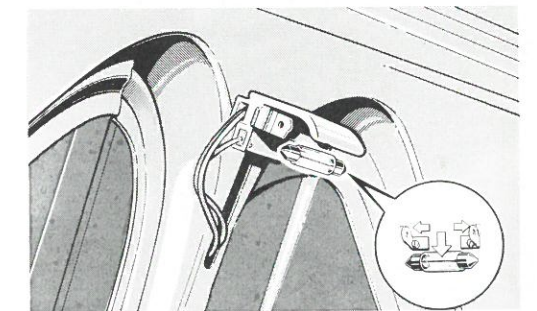
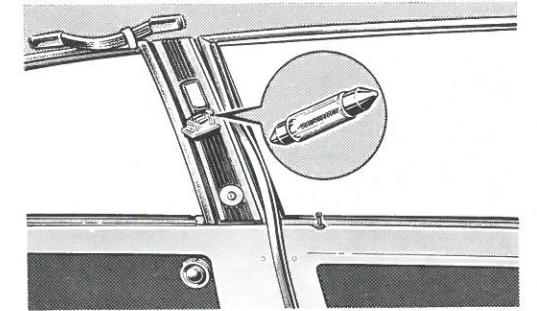

For renewing the bulbs of engine compartment and boot lights, take apart the contact springs and remove bulb.

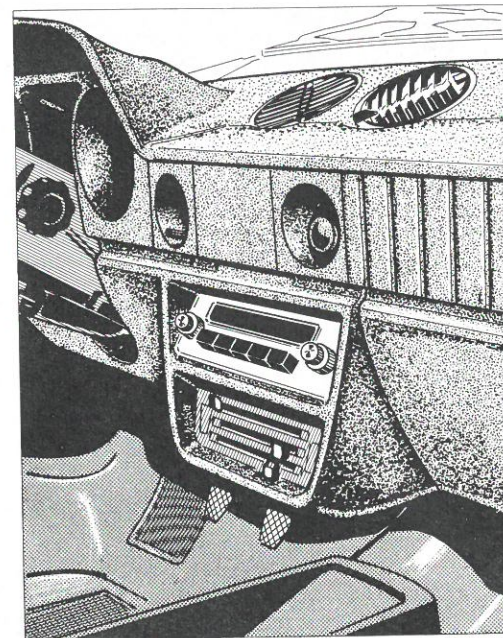
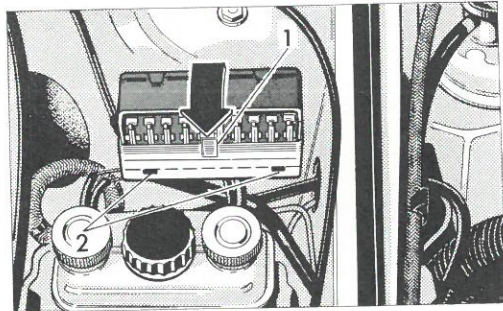

FUSEBOX

The fusebox is at scuttle in the engine compartment. The circuits protected by fuses, identified by item numbers (in relief on fusebox cover) are as listed below:

8 Amp Fuses (black)

- 1 - L.H. low beam
- 2 - R.H. low beam
- 3 - L.H. high beam
- 4 - R.H. high beam
- 5 - L.H. front and R.H. rear parking lights - L.H. number plate light
- 6 - R.H. front and L.H. rear parking light - R.H. number plate light

16 Amp Fuses (green)

- 7 -
 - 8 -
 - 9 -
 - 10 -
- } Main devices

To remove the fusebox cover, slightly press the knob 1 downward while at the same time moving the cover in the direction shown by the arrow to free the tabs 2 at the cover bottom from their seats in the fusebox; for refitting the cover, first insert the tabs into their seats, then rotate the cover and, by applying a light pressure to the knob 1, close it against the fusebox.

RADIO INSTALLATION

Provision is made for the installation of the radio equipment. The engine ignition system is of the radio interference suppressor type. The location for the radio set and the speakers is over the heater control panel and in door trim panels respectively.

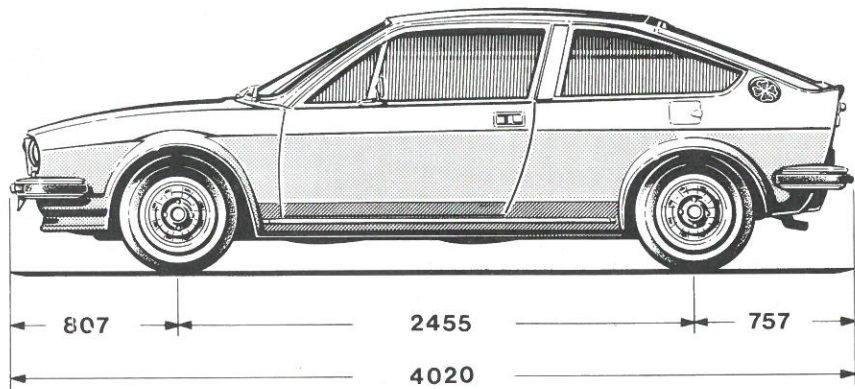
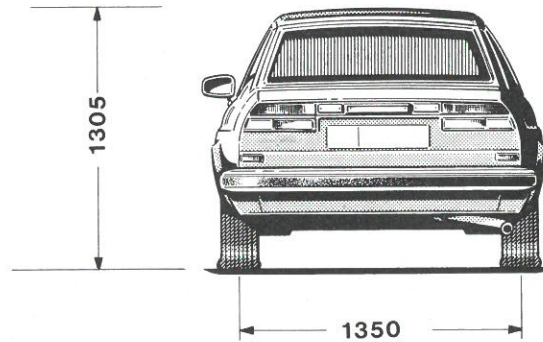
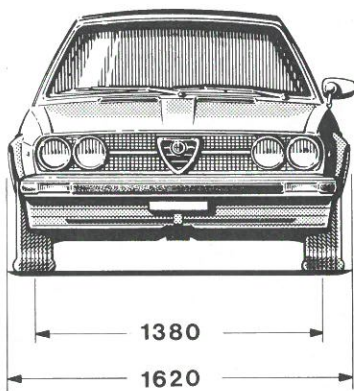

SPECIFICATION

ENGINE

Number of cylinders (horizontally opposed) . . . 4
 Bore mm 80
 Stroke mm 64
 Total displacement . . . cc 1286

Max. power BHP SAE 87 (64 kW)
 (at 6,000 rpm) BHP DIN 76 (56 kW)

CHASSIS

Min. turning circle . . . mm 9400
 Number of seats 5

Tyres { 145 SR 13
 165/70 SR 13

Capacity of boot dm³ 325
 Kerb weight (full tank) kg 890
 Towing gross weight . kg 800

PERFORMANCE

(with 37 : 9 final drive)

AFTER RUNNING IN						
maximum speeds - Kph						
1st	2nd	3rd	4th	5th	Rev.	
42	73	105	135	165	48	

The performances given are related to the use of the vehicle in normal travelling conditions in Central Europe.

The maximum speeds indicated should not be exceeded or mechanical damage may result.

VALVE TIMING

intake valves	Opening (before TDC)	12°
	Closing (after BDC)	48°
exhaust valves	Opening (before BDC)	45°
	Closing (after TDC)	7°

VALVE CLEARANCE (cold engine)

intake:	0.35 - 0.40 mm
exhaust:	0.45 - 0.50 mm

IGNITION

firing order:	1-3-2-4
static advance (1st mark):	7°-9° B.T.D.C.
intermediate advance (2nd mark):	21°-23° at 2000 r.p.m. B.T.D.C.
maximum advance (3rd mark):	35°-37° over 4500 r.p.m. B.T.D.C.

CARBURETTOR SETTING

Setting	Weber 32DIR 61/250	
	1st Barrel	2nd Barrel
Main jet	122	130
Main air metering jet	180	170
Idling jet	50	50
Idling air metering jet	170	115
Adjuster hole	50	—
Accelerator pump jet	45	—
Venturi (mm)	23	24

Idle speed: 800/900 r.p.m.
 CO percentage in exhaust gases: 1.5-2% (in volume) at the above stated idle speed

TRANSMISSION RATIOS

(37 : 9 final drive)

Speed	Gearbox	Overall
1st	3.545 : 1	14.573 : 1
2nd	2.062 : 1	8.474 : 1
3rd	1.434 : 1	5.893 : 1
4th	1.115 : 1	4.582 : 1
5th	0.931 : 1	3.826 : 1
Rev.	3.091 : 1	12.707 : 1

FRONT WHEEL TOE OUT

Toe-out as measured on a 13.4 in. (340 mm) dia. circle: 0.08 ± 0.04 in (2 ± 1 mm) (with car under static load).

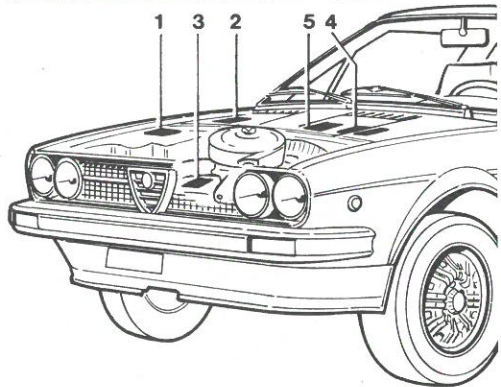

IDENTIFICATION

Identification plates or metal stamping are located as follows:

- 1 - **On R.H. front wheelarch:**
Identification plate (car model & type approval).
 - 2 - **On right side of intermediate bulkhead panel:**
Chassis serial no. (metal stamped).
 - 3 - **On crankcase:**
Engine no. (metal stamped on right bank at no. 3 cylinder).
 - 4 - **On inner side of bonnet:**
Lubrication plate.
 - 5 - **On inner side of bonnet:**
Finish plate (paint type & make).
- On contacting the Factory or a Member of our Service Organization please state: car model, chassis no. registration date, distance covered and car's purchase data.

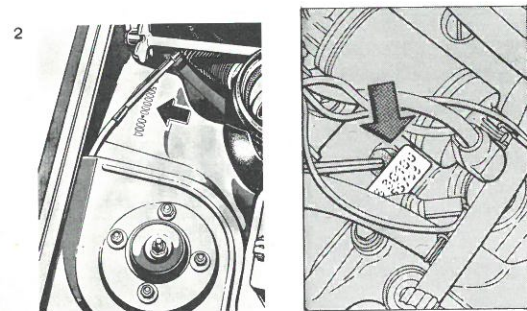
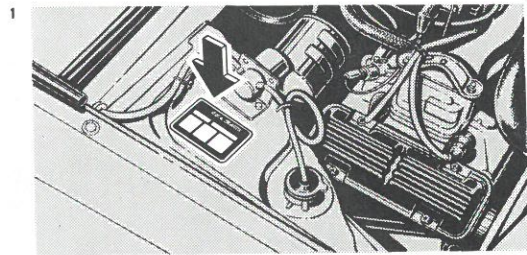

TRAILER HITCH INSTALLATION DIRECTIONS

This model can haul 800 kg gross weight trailer when provided with a suitable towing bracket. The towing bracket meets the relevant regulations and standards and should be fitted to the car body according to the directions outlined below.

Towing bracket components may vary in size or location, provided the attachment points to car frame and the general arrangement of bracket remain unchanged.

A support for attaching the electrical connection to the trailer electrical system should be installed in the most suitable position. For mechanical connection between towing bracket and trailer tongue, the following should be used:

- Ball hitch "CUNA 50" type (CUNA Std. NC 138-10).
- Ball socket "CUNA 50" type (CUNA Std. NC 438-15).

BRAKES

The trailer's braking system must be fully independent from the car's hydraulic brake system which must in no way be tampered with.

IMPORTANT NOTICE

The car/trailer unit should comply with the local regulations. **The trailer gross weight is the actual trailer gross load including all accessories and cargo loads.**

Therefore, it should be advisable before departing to check that the trailer gross weight does not exceed the prescribed limits. In any event, the trailer tongue load should never exceed 50 kg.

Increase tyre inflation pressure as directed in the footnote to tyre pressure table on inside backcover.

ELECTRICAL SYSTEM

For electrical connection a 12 Volt, 7-way connector (CUNA Std. NC 165-30) should be used.

When hooking up the connector to the car's wiring harness the following precautions should be observed:

- Make sure that wires does not interfere with the exhaust pipes.
- Fit grommets to the holes for passage of wires.
- Change the turn signal flasher with another one having a three 21 Watt bulb capacity so as to ensure proper operation of turn signals.
- Earth together car and trailer by means of the 7-way connector (use 2.5 sq. mm gauge wire).

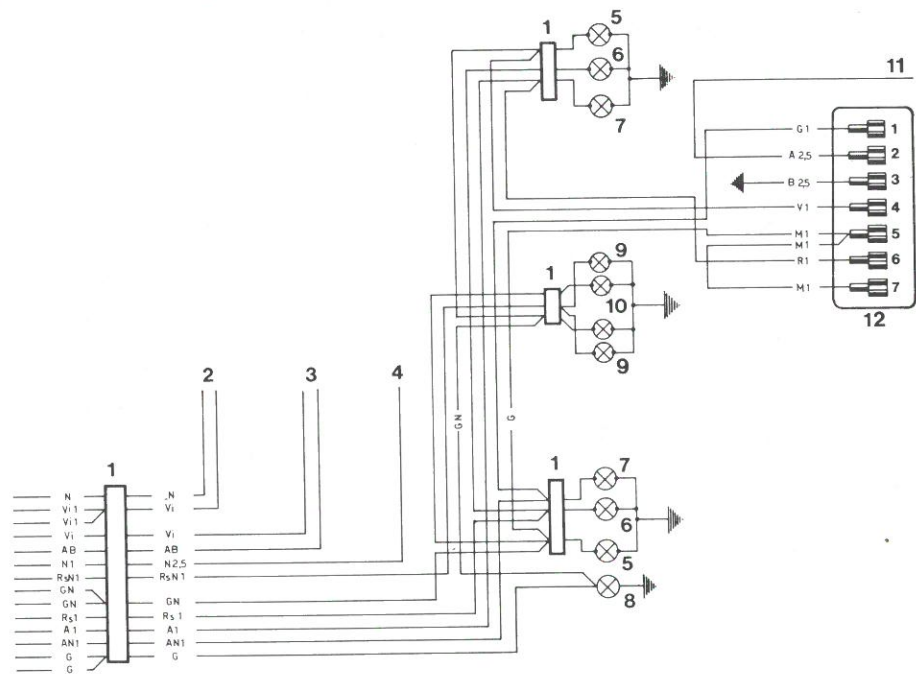

WIRING DIAGRAM FOR CONNECTION TO TRAILER

- | | |
|---------------------------------|--|
| 1 Junction boxes and connectors | 7 Rear direction indicators |
| 2 Courtesy light wire | 8 Boot light |
| 3 Fuel level indicator wires | 9 Reversing lights |
| 4 Heated backlight feed wire | 10 Number plate lights |
| 5 Rear parking lights | 11 Cable to feed possible electric brake |
| 6 Stop lights | 12 7-way connector |

NOTE: Alfa Romeo incurs no responsibility for trailer hitch installation not complying with the specified data.

Ball Hitch, Cuna Std. NC 136-10

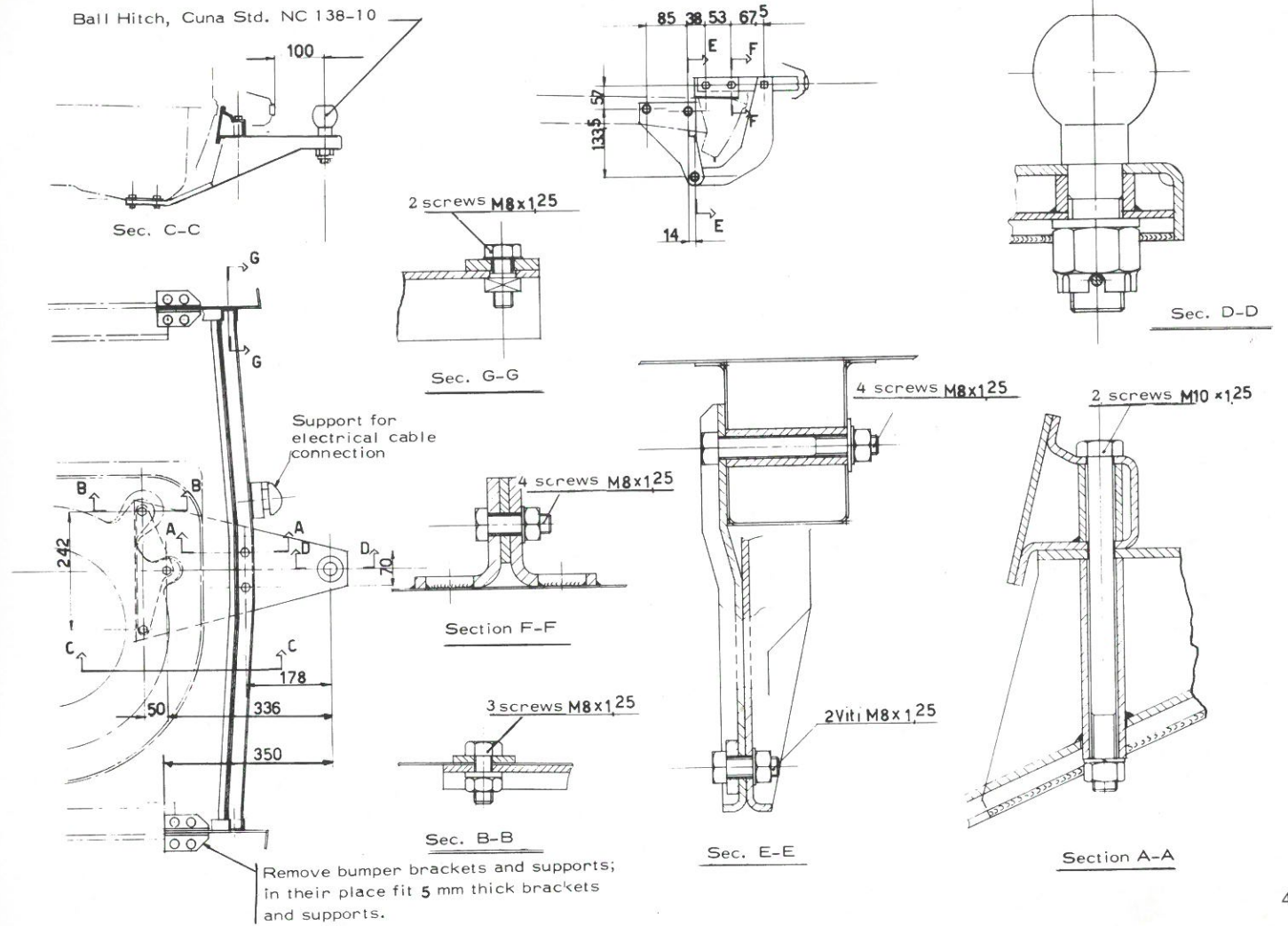

WIRING DIAGRAM

- 1 - Side direction indicator bulb 4 W
- 2 - Front direction indicators bulb 21 W
- 3 - Headlamp high beam bulb 55 W halogen
- 4 - Headlamp low beam bulb 55 W halogen
- 5 - Front parking lights bulb 4 W
- 6 - Engine compartment bulb 5 W
- 7 - Horns
- 8 - Battery 12 V - 43 Ah (60 Ah for export to Norway, Denmark, Finland)
- 9 - Starting motor
- 10 - Alternator
- 11 - Electric fan
- 12 - Thermal switch for electric fan
- 13 - Voltage regulator
- 14 - Oil pressure telltale switch
- 15 - Thermal switch for coolant temperature telltale
- 16 - Electrical screen washer pump
- 17 - Windscreen wiper (two-speed)
- 18 - Oil pressure gauge sender
- 19 - Thermal switch for coolant temperature tell tale
- 20 - Blower motor (two-speed)
- 21 - Distributor
- 22 - Coil
- 23 - Fusebox
- 24 - Reversing light switch
- 25 - Glovebox light bulb 5 W
- 26 - Switch for glovebox light
- 27 - Stop light switch
- 28 - Relay for flashing and dipping
- 29 - Auxiliary headlamp relay
- 30 - Horn relay
- 31 - Heated rear window relay
- 32 - Cigar lighter bulb 4 W
- 33 - Cigar lighter
- 34 - Ash tray and clock light bulb 1.2 W
- 35 - Clock
- 36 - Heater control panel light bulb 1.2 W
- 37 - Tachometer
- 38 - Fuel reserve warning light bulb 1.2 W
- 39 - Instrument light bulb 1.2 W
- 40 - Coolant temperature warning light bulb 1.2 W
- 41 - Choke and brake fluid level warning light bulb 1.2 W
- 42 - Oil pressure warning light bulb 1.2 W
- 43 - Coolant thermometer

- 44 - Alternator warning light bulb 1.2 W
- 45 - Oil pressure gauge
- 46 - Parking light warning bulb 1.2 W
- 47 - Direction indicator warning light bulb 1.2 W
- 48 - High beam warning light bulb 1.2 W
- 49 - Speedometer
- 50 - Choke control and warning light switch
- 51 - Ignition and starting switch
- 52 - Switch for blower motor, windscreen wiper motor, horn control, screen washer
- 53 - Direction indicators, parking lights, headlamps and flashing switch
- 54 - Dimmer of instrument, clock, heater control panel lights and parking lights tell tale
- 55 - Direction indicator flasher
- 56 - Switch on door jambs for courtesy light
- 57 - Switch for low brake fluid level warning light
- 58 - Courtesy light bulb 5 W
- 59 - Courtesy light switch
- 60 - Switch for heated rear window
- 61 - Bulb of heated window telltale (in switch) 1.2 W
- 62 - Heated rear window
- 63 - Fuel level sender
- 64 - Rear parking lights bulb 5 W
- 65 - Stop lights bulb 21 W
- 66 - Rear direction indicators bulb 21 W
- 67 - Reversing lights bulb 21 W
- 68 - Number plate light bulb 5 W
- 69 - Boot light bulb 5 W
- 70 - Road hazard light switch
- 71 - Road hazard warning light in switch 1.2 W

CABLE COLOUR CODE

A	bleu	Vi	violet
G	yellow	AB	blue/white
Gr	grey	AN	blue/black
M	brown	BN	white/black
N	black	GN	yellow/black
Rs	red	GrN	grey/black
S	pink	RsN	red/black
V	green	VN	green/black

The figure following the colour code on the diagram shows the wire gauge in mm².
Where not shown the wire gauge is 0.5 mm².

utgång 1 grå Hellyus OK.
" 2 gråsvart Hellyus OK
" 3 grön Hellyus OK
"

W

bulb 1.2 W
2 W

switch

screen wiper motor, horn
bells, headlamps and flashing
heater control panel lights

side light
warning light

switch 1.2 W

1 W

switch 1.2 W

1
/white
/black
e/black
w/black
/black
black
n/black

on the diagram shows the
1.5 mm².

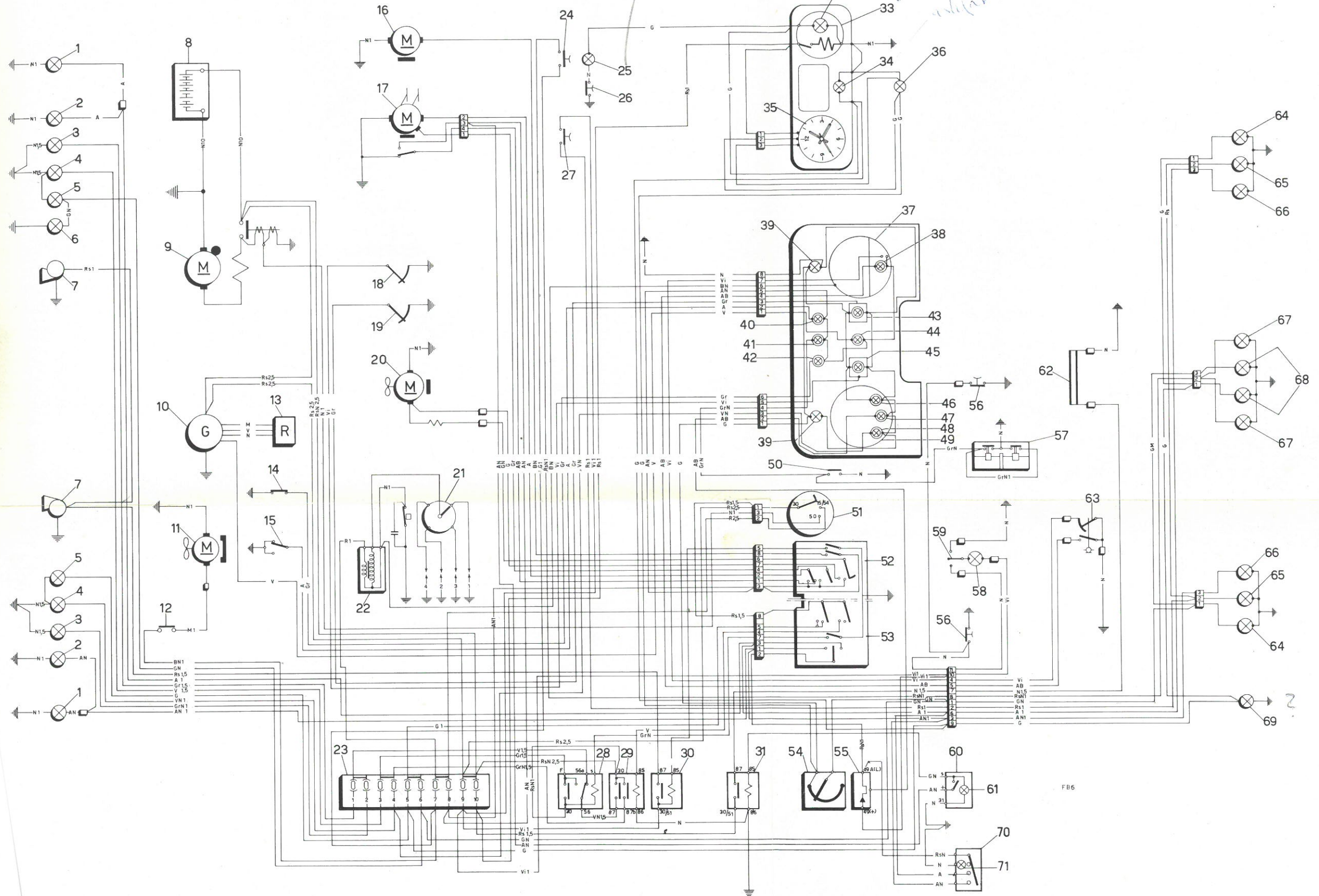

FB6